



Congratulations !

The **90-FLT** is complete water quality logger in a single portable unit. It combines Dissolved Oxygen, Conductivity, TDS, pH, mV, Turbidity and Temperature.

Despite its impressive list of features, the **90-FLT** is a breeze to operate. This manual has been designed to help you get started, and also contains some handy application tips. If at any stage you require assistance, please contact either your local TPS representative or the TPS factory in Brisbane.

The manual is divided into the following sections:

1. Table of Contents

Each major section of the handbook is clearly listed. Sub-sections have also been included to enable you to find the information you need at a glance.

2. Introduction

The introduction has a diagram and explanation of the display and controls of the **90-FLT**. It also contains a full listing of all of the items that you should have received with unit. Please take the time to read this section, as it explains some of items that are mentioned in subsequent sections.

3. Main Section

The main section of the handbook provides complete details of the **90-FLT**, including operating modes, calibration, troubleshooting, specifications, and warranty terms.

4. Appendices

Appendices containing background information and application notes are provided at the back of this manual.

TPS Pty Ltd
4 Jamberoo Street
Springwood, Brisbane,
Australia, 4127

Phone : (07) 32 900 400
International : 61 7 32 900 400

Fax : (07) 3808 4871
International : 61 7 3808 4871

E-mail : tps@tps.com.au

Web Site : www.tps.com.au

90-FLT
Dissolved Oxygen,
Conductivity, TDS, pH, mV,
Turbidity, Temperature
Logger

Date : 20-Mar-2008

Version : 9.01

Contents

1. Introduction	4
1.1 90-FLT Display and Controls	4
1.2 90-FLT Left Side Connectors	4
1.3 90-FLT Right Side Connectors	5
1.4 Menu and Function Keys	5
1.5 One-Touch Keys	5
1.6 Numeric Keys.....	5
1.7 Enter Key	5
1.8 Delete Key.....	5
1.9 ON and OFF Keys.....	5
1.10 80 Character Display	5
1.11 Unpacking Information	6
1.12 Specifications	7
2. 90-FLT Menu Structure	11
3. Dissolved Oxygen Mode.....	12
3.1 Selecting Dissolved Oxygen Mode	12
3.2 Dissolved Oxygen Calibration	12
3.3 Dissolved Oxygen Calibration Notes	15
3.4 Dissolved Oxygen Calibration Messages.....	15
3.5 Dissolved Oxygen Stirrer	16
4. Conductivity Mode	17
4.1 Selecting Conductivity Mode.....	17
4.2 Setting the Conductivity calibration standard	17
4.3 Setting the Conductivity sensor k factor	18
4.4 Conductivity Calibration.....	19
4.5 Conductivity Calibration Notes.....	20
4.6 Conductivity Calibration Messages	20
5. TDS Mode.....	21
5.1 Selecting TDS Mode	21
5.2 Setting the TDS calibration standard	21
5.3 Setting the TDS sensor k factor.....	22
5.4 TDS Calibration	23
5.5 TDS Calibration Notes	24
5.6 TDS Calibration Messages.....	24
6. pH Mode	25
6.1 Selecting the pH Buffer Set.....	25
6.2 pH Calibration	26
6.3 pH Calibration Notes.....	27
6.4 pH Calibration Messages	28
7. Millivolt Mode	29
7.1 Millivolt Measurements	29
8. Turbidity Mode	30
8.1 Fitting the Cable to the Sensor	30
8.2 Fitting the Protector to the Sensor.....	31
8.3 Setting the Turbidity calibration standard	32
8.4 Turbidity Calibration.....	33
8.5 Turbidity Calibration Notes	34
8.6 Calibration Messages	34
9. Temperature Mode	35
9.1 Temperature Calibration	35
9.2 Temperature Calibration Notes	36
9.3 Calibration Messages	36
9.4 Manual Temperature Setting.....	37

10.	Good Laboratory Practices (GLP)	38
10.1	To recall GLP information on the display	38
10.2	Failed Calibration.....	40
10.3	Printing GLP Information to the RS232 Port.....	40
10.4	Instrument Serial Number	41
10.5	Additional GLP Features	41
11.	Datalogging	42
11.1	Setting the A & B Data Input Function.....	42
11.2	Manually Recording Readings into the Logger	42
11.3	Automatic Datalogging.....	45
11.4	Recalling Readings from the Logger	49
11.5	Erasing Records from the Logger	50
11.6	Printing Records from the Logger to the RS232 Port.....	50
12.	RS232 Port	51
12.1	Setting the Baud Rate.....	51
12.2	Sending Readings to the RS232 Port	51
12.3	RS232 Configuration	51
12.4	Communication and Statistical Software.....	51
12.5	Commands	51
12.6	Data Format	53
12.7	GLP Data Format.....	55
12.8	Importing Data into Microsoft Excel.....	56
13.	Setting the Clock	58
14.	Initialising the 90-FLT	59
15.	Instrument firmware version number	59
16.	Battery Saver Function	60
17.	Moisture Protection	61
17.1	Silica Gel Pack.....	61
18.	Troubleshooting	62
18.1	General Errors.....	62
18.2	Dissolved Oxygen Troubleshooting.....	63
18.3	Conductivity / TDS Troubleshooting.....	64
18.4	Ph and Redox Troubleshooting.....	65
18.5	Turbidity Troubleshooting	66
18.6	Temperature Troubleshooting.....	66
19.	Appendices	67
19.1	Dissolved Oxygen.....	67
19.2	Conductivity/TDS	70
19.3	pH.....	72
20.	Warranty	76

1. Introduction

1.1 90-FLT Display and Controls

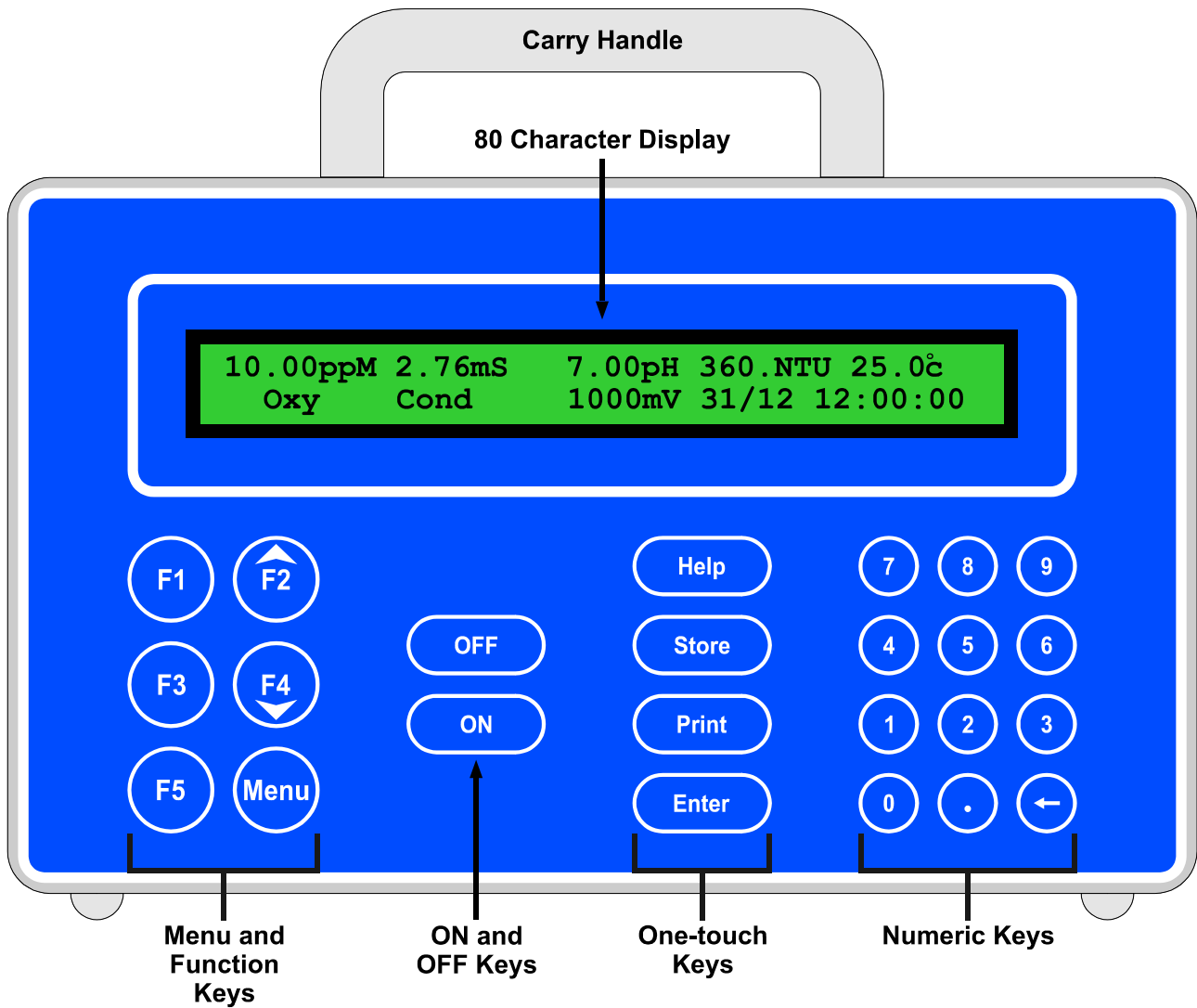

1.2 90-FLT Left Side Connectors

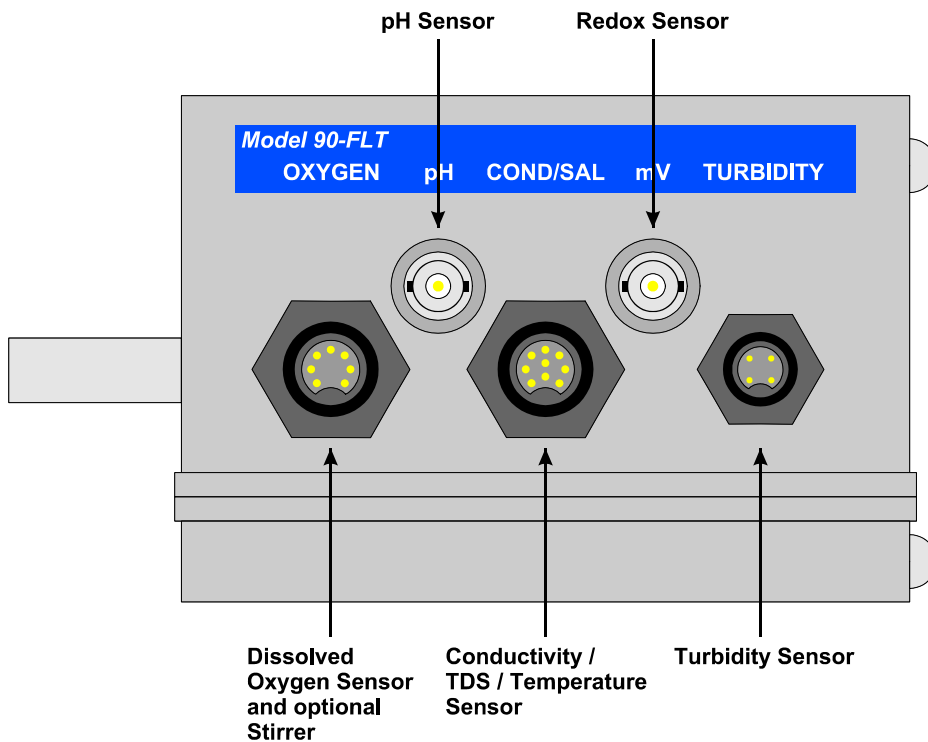

1.3 90-FLT Right Side Connectors

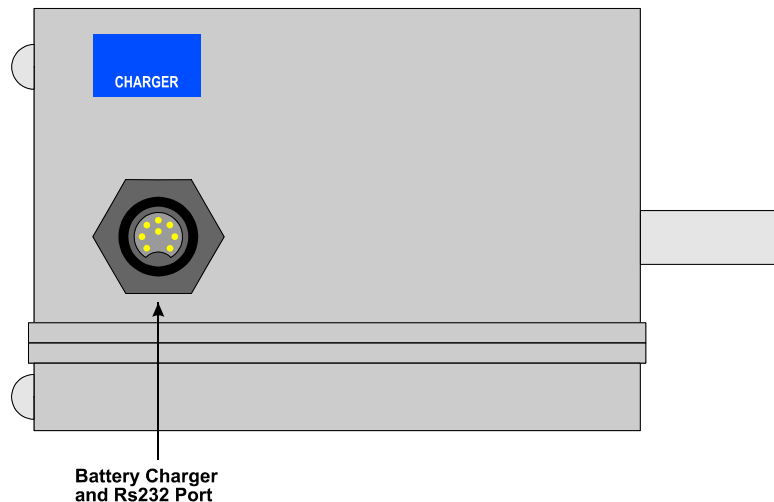

1.4 Menu and Function Keys

Press the **F1** to **F5** function keys to select desired options within the menu system.

Additionally, these keys perform the following function directly in normal measurement mode...

- F2** : Press to start and stop the optional Dissolved Oxygen stirrer. See section 3.5.
- F4** : Press to start automatic datalogging in the Sampling Period and Duration mode. See section 11.3.3.

1.5 One-Touch Keys

- Help** : Press to obtain context-sensitive help messages. This function is disabled within menus.
- Store** : Press to record readings into the Logger. See section 11.
- Print** : Press to transmit current reading plus date and time to the RS232 port. See section 12.2.
- Enter** : Press the **Enter** key to accept default values or those entered on the Numeric Keypad.

1.6 Numeric Keys

Used to enter values during set-up and calibration. A negative sign and decimal point are provided.

1.7 Enter Key

Press the **Enter** key to accept default values or those entered on the Numeric Keypad.

1.8 Delete Key

Press the **←** key to make corrections to values entered on the Numeric Keypad.

1.9 ON and OFF Keys

Press the relevant key to switch the **90-FLT** on and off as required.

1.10 80 Character Display

80 character alphanumeric display with user-friendly menu and context-sensitive help system. Shows Dissolved Oxygen, Conductivity/TDS, pH, mV, Turbidity, Temperature, Date and Time simultaneously.

1.11 Unpacking Information

Before using your new **90-FLT**, please check that the following accessories have been included:

	Part No
Standard Kit...	
1. 90-FLT Field Lab.....	126105
2. pH6.88 Buffer, 200mL	121306
3. pH4.00 Buffer, 200mL	121381
4. 2.76 mS/cm Conductivity Standard, 1 Litre	122305
5. 36.0 ppK Salinity Standard, 1 Litre (if ordered with k=10)	122304
6. 2.00 ppK TDS Standard, 1 Litre (if ordered with k=1.0)	122309
7. 900 NTU Secondary Standard, 200mL	125220
8. 90 NTU Secondary Standard, 200mL	125216
9. Plug-Pack Power Supply	130009
10. 90-FLT Handbook	130050

Sensors...

1. ENDC Turbidity Sensor (no cable)	125186
2. ENDCC Detachable Cable for ENDC Turbidity Sensor, 5m.....	125187
3. YSI Field type DO ₂ sensor (no cable)	123204
4. 3m Cable for YSI Field DO ₂ sensor	123215
5. 5m Cable for YSI Field DO ₂ sensor	123219
6. 7.5m Cable for YSI Field DO ₂ sensor	123216
7. 15m Cable for YSI Field DO ₂ sensor	123217
8. YSI Non-stirring DO ₂ sensor for BOD bottles	123214
9. YSI Self-stirring DO ₂ sensor for BOD bottles	123213
10. k=10/ATC/Temp Conductivity Sensor, 5m.....	122218
11. k=1/ATC/Temp Conductivity Sensor, 5m.....	122196
12. Submersible pH Sensor, Gel Filled, 5m	111224
13. Intermediate Junction pH Sensor, 5m.....	111227
14. Submersible Redox Sensor, Gel Filled, 5m.....	111260
15. Intermediate Junction Redox Sensor, 5m	121267
16. Temperature Sensor, 5m.....	124210
(not required when Conductivity sensor is in use)	

Options...

1. Protector cover for ENDC Turbidity Sensor	125189
2. PVC Sensor holder assembly, 5m s/s cable.....	121345
3. Dissolved Oxygen stirrer, 5m.....	123306
4. Extended cable for sensors (order by the metre).....	130040
5. RS232 Serial Interface Cable	130015
6. USB to Serial Adaptor (requires 13015 also).....	130087
7. Communication software for Windows 95 and all later versions	130086
8. Solar Panel.....	130012
9. Clip lead for external 12V DC battery.....	130013
10. Hard Carry case for meter and accessories.....	130058

Spares...

1. 7.2V NiCad Battery Pack	130027
2. Membrane, Filling Solution and Zero DO ₂ kit	123300

Turbidity standards are available in other values. Please contact your distributor or TPS if you need standards that are closer to your expected range of measurements.

1.12 Specifications

1.12.1 Dissolved Oxygen

Range	Resolution	Accuracy
0 to 32.00 ppM	0.01 ppM	±0.02 ppM
0 to 320.0 % Saturation	0.1 % Saturation	±0.3 % Saturation
0 to 66.0 % Gaseous	0.1 % Gaseous	±0.1 % Gaseous
Note : Full scales are subject to sensor performance.		

Sensor Type..... Clark type polarographic sensor with in-built ATC.

Salinity Correction for ppM..... 0 to 50.0 ppK, automatic using conductivity/TDS reading.

Temperature Compensation..... Automatic for membrane permeability.
Automatic for Dissolved Oxygen solubility in ppM mode.

Calibration Automatic zero and span calibration.

Sensor Span Range..... 65 to 200 %

1.12.2 Conductivity

Ranges	Resolution	Accuracy
k=0.1 Sensor		
0 to 2.000 uS/cm	0.001 uS/cm	±0.5% of full scale of selected range at 25 °C
0 to 20.00 uS/cm	0.01 uS/cm	
0 to 200.0 uS/cm	0.1 uS/cm	
0 to 2000 uS/cm	1 uS/cm	
k=1.0 Sensor		
0 to 20.00 uS/cm	0.01 uS/cm	±0.5% of full scale of selected range at 25 °C
0 to 200.0 uS/cm	0.1 uS/cm	
0 to 2000 uS/cm	1 uS/cm	
0 to 20.00 mS/cm	0.01 mS/cm	
k=10 Sensor		
0 to 200.0 uS/cm	0.1 uS/cm	±0.5% of full scale of selected range at 25 °C
0 to 2000 uS/cm	1 uS/cm	
0 to 20.00 mS/cm	0.01 mS/cm	
0 to 200.0 mS/cm	0.1 mS/cm	
Note : Ranges are automatically selected. Exact auto-ranging points and full scales are subject to sensor performance.		

Sensor Type..... Ryton[®] plastic body with two platinised platinum plates with in-built ATC.

Temperature Compensation..... Automatic, 0 to 100 °C.
(standard Conductivity sensor is limited to 60 °C).

Calibration Automatic zero and span calibration.

Sensor Span Range..... ±25% of nominal k factor.

1.12.3 TDS

Ranges	Resolution	Accuracy
<i>k=0.1 Sensor</i>		
0 to 1.000 ppM 0 to 10.00 ppM 0 to 100.0 ppM 0 to 1000 ppM	0.001 ppM 0.01 ppM 0.1 ppM 1 ppM	±0.5% of full scale of selected range at 25 °C
<i>k=1.0 Sensor</i>		
0 to 10.00 ppM 0 to 100.0 ppM 0 to 1000 ppM 0 to 10.00 ppK	0.01 ppM 0.1 ppM 1 ppM 0.01 ppK	±0.5% of full scale of selected range at 25 °C
<i>k=10 Sensor</i>		
0 to 100.0 ppM 0 to 1000 ppM 0 to 10.00 ppK 0 to 100.0 ppK	0.1 ppM 1 ppM 0.01 ppK 0.1 ppK	±0.5% of full scale of selected range at 25 °C
Note : Ranges are automatically selected. Exact auto-ranging points and full scales are subject to sensor performance.		

Sensor TypeRyton[®] plastic body with two platinised platinum plates with in-built ATC.

Temperature CompensationAutomatic, 0 to 100 °C.
(standard Conductivity sensor is limited to 60 °C).

Calibration.....Automatic zero and span calibration.

Sensor Span Range±25% of nominal k factor.

1.12.4 pH

Range	Resolution	Accuracy
0 to 14.00 pH	0.01 pH	±0.01 pH

Sensor TypeGlass bulb pH sensor, combination or half cell.

Input Impedance.....>3 x 10¹² Ohms

Temperature CompensationAutomatic, 0 to 100 °C.

Calibration.....Automatic asymmetry and slope calibration.

Automatic Buffer Recognition.....pH4.00, pH6.88, pH7.00, pH9.23 & pH10.06.
Any other can be entered during calibration.

Sensor Asymmetry Range-1.00 to 1.00 pH

Sensor Slope Range.....85.0 to 105.0 %

1.12.5 Turbidity

Ranges	Resolution	Accuracy
0 to 200.0 NTU	0.1 NTU	±1 NTU
200 to 2000 NTU	1 NTU	

Sensor Type..... High sensitivity turbidity probe measuring light scattered at 90° according to ISO7027.

Calibration Automatic in Zero and Turbidity standard.

Turbidity Standards..... Low Range : User-set from 30.0 to 180.0 NTU.
 High Range : User-set from 300 to 2000 NTU.

The optical components contained within the Turbidity Sensor are covered by US Patent number 6,842,243.

1.12.6 Millivolts

Ranges	Resolution	Accuracy
0 to ±2000 mV	1 mV	±1 mV

Sensor Type..... Platinum tip ORP sensor, combination or half cell.
 Ion Selective Electrodes can also be used in this mode.

Input Impedance >3 x 10¹² Ohms

1.12.7 Temperature

Range	Resolution	Accuracy
-30.0 to 110.0 °C	0.1 °C	±0.2 °C
Note : When using Conductivity/TDS sensor for Temperature readout, sensor is limited to 60 °C.		

Sensor Type..... Silicon transistor built into tip of Conductivity/TDS sensor, or separate Temperature sensor if Conductivity / TDS sensor is not in use.

Calibration Automatic offset and span calibration.

Sensor Offset Range -15.0 to 15.0 °C

Sensor Span Range 93 to 107 %

1.12.8 General Specifications

Memory	6520 readings including date and time with A&B function disabled. 5440 readings including date and time with A&B function enabled.
Automatic Logging	<p>Rate per Day 1 to 288 readings per day.</p> <p>Time of Day 1 to 12 discrete times of the day, in 24 hour format.</p> <p>Sampling Period and Duration One reading every 1 to 300 seconds for a duration of 1 to 720 minutes or continuous.</p>
RS232 Port	300, 9600 & 19200 baud. 8 bits, no parity, 1 stop bit, XON/XOFF Protocol.
Clock	Calendar clock displays date, month, hours, minutes & seconds. Year is Y2K compliant and is attached to all stored data.
Good Laboratory Practices	Date, time and results of last calibration for all parameters are stored. This information can be recalled or sent to the RS232 port at any time.
Power	7.2V, 1300mAH NiCad battery built in. Battery charger for country of destination is included. Solar panel and external battery clip lead optionally available.
Battery Saver	Auto switch-off after 5 minutes or 1 hour. Battery saver can be switched off to allow continuous use.
Dimensions	230 x 140 x 100 mm
Mass	Instrument only : Approx. 1.5 kg Full Kit : Approx. 7.0 kg
Environment	Temperature : 0 to 45 °C Humidity : 0 to 90 % R.H.

2. 90-FLT Menu Structure

A detailed breakdown of the menu system of the **90-FLT** is shown below. This diagram provides a quick reference for the menu functions available for the **90-FLT**.

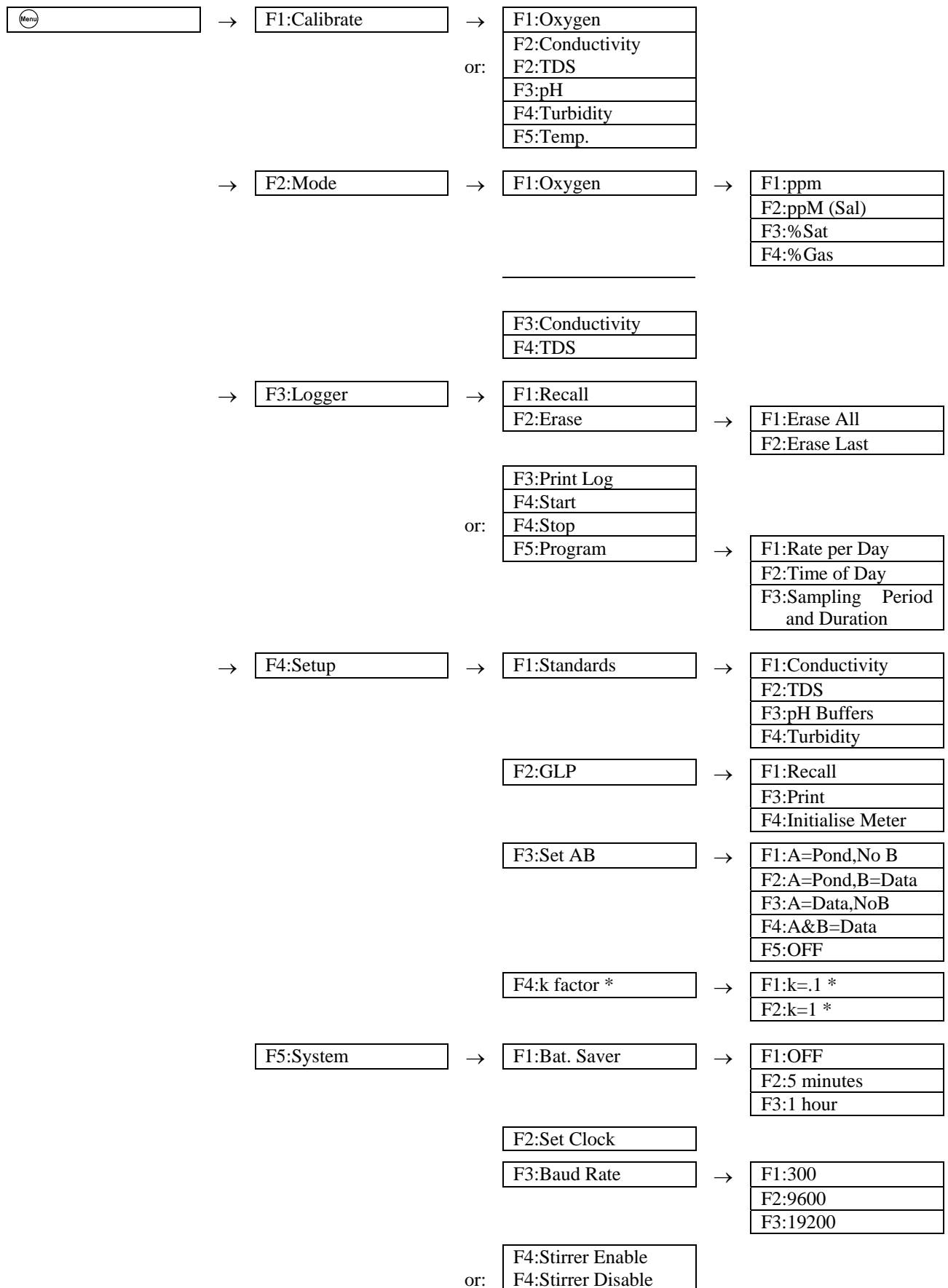

* This function not available when a TPS k=10 sensor is connected.

3. Dissolved Oxygen Mode

3.1 Selecting Dissolved Oxygen Mode

1. Select Dissolved Mode (Menu → **F2:Mode** → **F1:Oxygen**).
2. The Dissolved Oxygen readout units selection screen is now displayed...

MODE	F1:ppm	F2:ppM (Sal)
	>F3:% Sat	F4:% Gas

The arrow indicates the current selection.

Press **F1** to select Dissolved Oxygen readout in ppm units. This selection will not apply Salinity correction to the displayed readings.

Press **F2** to select Dissolved Oxygen readout in Salinity-corrected ppM units. This selection will use the Conductivity or TDS reading for automatic salinity correction.

Press **F3** to select Dissolved Oxygen readout in % Saturation units.

Press **F4** to select Dissolved Oxygen readout in % Gaseous units.

Press **Menu** to quit without changing the current setting.

3.2 Dissolved Oxygen Calibration

1. Plug the Dissolved Oxygen sensor into the **Oxygen** socket.
2. Select the Dissolved Oxygen readout mode to be used, as detailed in section 3.1.
3. Ensure that the Temperature readout has been calibrated (see section 9.1) or manually set (see section 9.4) when calibrating either of the ppM modes..
4. Rinse the Dissolved Oxygen sensor in distilled water and blot dry.

3.2.1 Zero Calibration (all Oxygen modes)

1. Place the Dissolved Oxygen sensor into an oxygen-free solution. This solution may be prepared by dissolving 2g of Sodium Sulphite in 100mL of distilled water. A 50g bottle of Sodium Sulphite powder (part number 123302) is supplied with a new Dissolved Oxygen sensor or Membrane Kit for this purpose.
2. Allow the reading to stabilise at or near zero. This may take 2-3 minutes.
3. Select Oxygen Calibration. (Menu → **F1:Calibrate** → **F1:Oxygen**)

When the reading is below approximately 25 % Saturation, 2 ppM or 5% Gaseous, the **90-FLT** will display the ZERO calibration screen...

1*0%Sat	25.0°C
Oxygen ZERO Calibration, Press Enter	

4. Press **Enter** to calibrate.

A "*" will not be removed from the display after a Zero Calibration.

5. Remove the sensor from the Zero solution, rinse well in distilled water and blot dry.

The **90-FLT** will now prompt you to perform an AIR calibration.

3.2.2 Span Calibration in Air (all Oxygen modes)

1. Hang the Dissolved Oxygen sensor in air. The tip of the Dissolved Oxygen sensor should be pointing downwards.

Allow the reading to stabilise. After a zero calibration, this may take up to 5 minutes.

2. Select Oxygen Calibration. (Menu) → **F1:Calibrate** → **F1:Oxygen**)

When the reading is above approximately 25% Saturation, 2 ppM or 5% Gaseous, the **90-FLT** will display the AIR calibration screen...

```
101.0%Sat                25.0°C
Oxygen  AIR  Calibration, Press Enter
```

Press (Enter) to calibrate.

A "*" in the display will be replaced by a decimal point after a successful air calibration.

3. The **90-FLT** is now calibrated and is ready for Dissolved Oxygen measurements. Rinse the Dissolved Oxygen sensor in distilled water and blot dry before placing it into unknown samples.

3.3 Dissolved Oxygen Calibration Notes

1. The relationship of % Saturation and ppM depends on a number of variables, so *always calibrate in the mode required*. Do not try to infer Oxygen content from one mode to another.
2. A zero calibration should be performed at least monthly. In applications where there is a low level of dissolved oxygen, a zero calibration may have to be done weekly.
3. An air calibration should be performed at least weekly. Of course, more frequent calibration will result in greater confidence in results.
4. All calibration information is retained in memory when the **90-FLT** is switched off. This information can be recalled or printed later using the GLP function (see section 10).

3.4 Dissolved Oxygen Calibration Messages

1. If a Zero calibration has been successfully performed, the **90-FLT** will display the following message and the Zero value of the sensor...

```

0.0%Sat                25.0°C
Calibration OK,      Zero=0.5%
  
```

2. If a Zero calibration has failed, the **90-FLT** will display the following message and the failed Zero value of the sensor. The unit will return to normal display mode with a “ * ” in place of the decimal point in the Dissolved Oxygen reading.

```

15.0%Sat                25.0°C
Calibration Failed, Zero=15.0%
  
```

3. If an Air/Span calibration has been successfully performed, the **90-FLT** will display the following message and the Span value of the sensor...

```

100.0%Sat              25.0°C
Calibration OK,      Span=100.0%
  
```

4. If an Air/Span calibration has failed, the **90-FLT** will display the following message and the failed Span value of the sensor. The decimal point will be replaced by a “ * ” when the unit returns to normal display mode.

```

205.0%Sat              25.0°C
Calibration Failed, Span=205.0%
  
```

5. The allowable Span range for a Dissolved Oxygen sensor is 65.0 to 200.0 %. If calibration fails due to the Span value being outside these limits, then please consult the Troubleshooting guide (section 18.2) for possible remedies.

3.5 Dissolved Oxygen Stirrer

The 90-FLT is equipped with a 4.5V DC output to power a stirrer for the Dissolved Oxygen sensor. This power output is suitable for the TPS submersible DO₂ stirrer (part number 123306).

3.5.1 Enabling and Disabling the Dissolved Oxygen stirrer output

1. Select the System menu (Menu → F5:System).
2. Select F4:Stirrer Enable or F4:Stirrer Disable from the menu as required.

3.5.2 Connecting the Dissolved Oxygen stirrer

To connect the Dissolved Oxygen stirrer...

1. Plug the Dissolved Oxygen stirrer into the **Oxygen** socket on the meter.
2. Plug the Dissolved Oxygen sensor into the in-line socket that is provided on the stirrer cable.

Please refer to the diagram below.

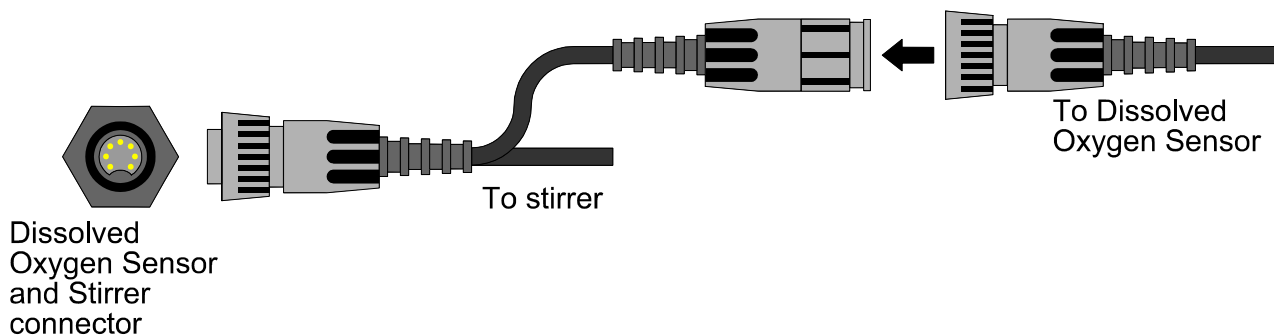

3.5.3 Starting and Stopping the Dissolved Oxygen stirrer

1. Ensure that the Dissolved Oxygen stirrer output has been enabled, as per section 3.5.1.
2. Press F2 once in normal display mode to start the stirrer. The stirrer will stay on for 40 seconds and then stop. A countdown is provided on the screen.
3. Press F2 a second time any time during the 40 second period to set the Dissolved Oxygen stirrer to operate continuously.
4. Press F2 a third time to stop the Dissolved Oxygen stirrer.

The Dissolved Oxygen stirrer starts and stops automatically when the 90-FLT is in Rate per Day or Time of Day automatic datalogging mode. See sections 11.3.1 and 11.3.2.

The Dissolved Oxygen stirrer will be stopped if a request for logged data is received by the RS232 port.

4. Conductivity Mode

4.1 Selecting Conductivity Mode

1. Select Conductivity Mode (Menu → **F2:Mode** → **F3:Conductivity**).
2. The **90-FLT** now proceeds to Conductivity measurement mode. Note that a “ * ” is shown in place of the decimal point until a successful calibration has been performed (see section 4.4).

4.2 Setting the Conductivity calibration standard

The factory default for this item is 2.76mS/cm. If this is satisfactory, go directly to section 4.3.

1. Select the Conductivity Standard entry

(Menu) → **F4:Setup** → **F1:Standards** → **F1:Conductivity**).

The following screen is now displayed...

```
Conductivity Standard:2760 uS
Range 20uS/cm to 2000mS/cm
```

2. Type in the value of the Conductivity standard that is to be used for calibration, including the decimal point. Use the \leftarrow key to make any corrections.
3. Press **Enter** to save the value of the standard solution.
Alternatively, press (Menu) to quit without changing the current setting.
4. The **90-FLT** will now ask you to enter the units for the Conductivity standard...

```
Conductivity Standard:2760
Select Units   F1:uS/cm   F2:mS/cm
```

Press **F1** to set the Conductivity Standard as uS/cm.

Press **F2** to set the Conductivity Standard as mS/cm.

5. The Conductivity standard is now programmed for use at calibration.

4.3 Setting the Conductivity sensor k factor

The **90-FLT** automatically recognises a k=10 sensor. If a k=10 sensor is being used, go directly to section 4.4.

The **90-FLT** **does not** automatically recognise k=0.1 or k=1 sensors. When a k=0.1 or k=1 sensor is used, the **90-FLT** must be set to the correct k factor before use.

To select a k=0.1 or k=1 sensor...

1. Select k factor entry (Menu) → **F4:Setup** → **F4:k factor**).
2. The k factor entry screen is now displayed...

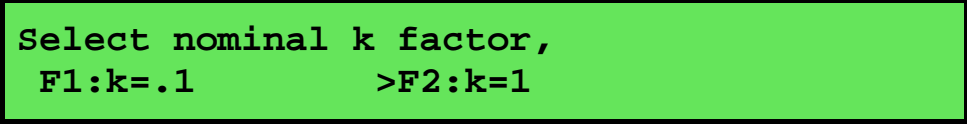

Select nominal k factor,
F1:k=.1 >F2:k=1

The arrow indicates the current selection.

Press (F1) if a k=0.1 sensor is being used.

Press (F2) if a k=1 sensor is being used.

Press (Menu) to quit without changing the current setting.

Notes

1. The manual k factor selection is kept in memory when the meter is switched off.
2. The manual k factor selection is reset to k=1 during initialisation.
3. The **90-FLT** will always automatically recognise a k=10 sensor, regardless of the manual k factor selection.
4. Calibration settings for k=0.1, k=1 and k=10 sensors are NOT stored separately.
The **90-FLT** requires re-calibration when a new k factor sensor is connected.

4.4 Conductivity Calibration

Before attempting a Conductivity calibration, ensure that the **90-FLT** has been set up correctly according to sections 4.1 to 4.3.

1. Plug the Conductivity sensor into the **Cond/Sal** socket.
2. Rinse the Conductivity sensor in distilled water. Shake off as much water as possible. Blot the outside of the sensor dry. **DO NOT BLOT THE ELECTRODE WIRES.**

Zero Calibration

3. Let the sensor dry in air.
4. Select Conductivity Calibration (Menu) → **F1:Calibrate** → **F2:Conductivity**).
5. The **90-FLT** will recognise the low conductivity signal and attempt a Zero calibration. For example...

```

0*01uS                               25.0°C
Cond. ZERO           Calibration, Press Enter
  
```

6. When the reading has stabilised at or near zero, press (Enter) to calibrate or (Menu) to quit. The “ * ” will not be removed after a zero calibration.

Standard Calibration

7. Place the Conductivity sensor into a sample of Conductivity standard. Ensure that it is immersed correctly, as per the diagram below.

DO NOT place the sensor directly into the bottle of standard. Discard the used sample of standard after use.

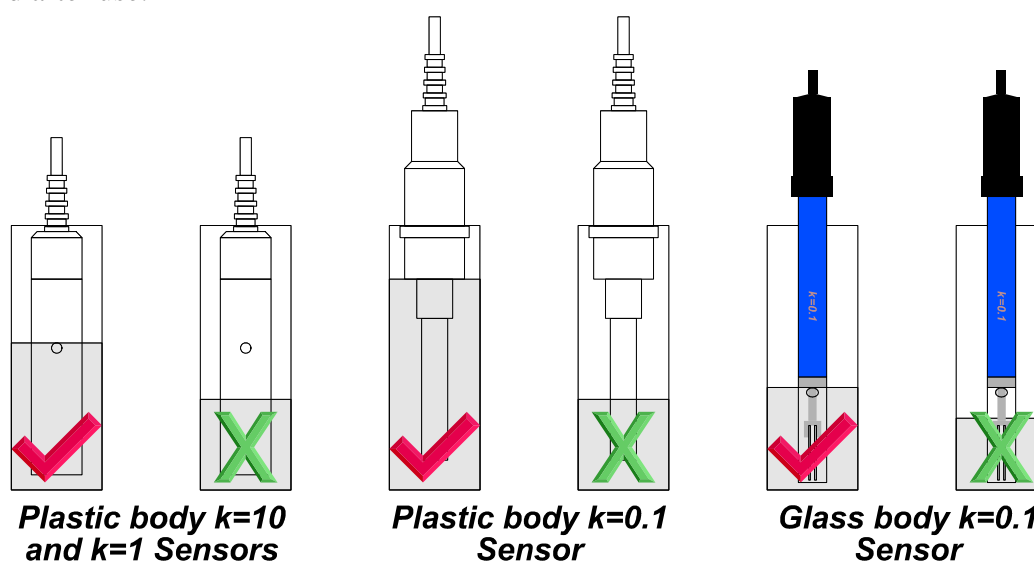

8. Select Conductivity Calibration (Menu) → **F1:Calibrate** → **F2:Conductivity**). The calibration screen will be displayed with the Conductivity standard to be used. For example...

```

2*86mS                               25.0°C
Cond. 2760uS           Calibration, Press Enter
  
```

9. When the reading has stabilised, press (Enter) to calibrate. The “ * ” will now be replaced by a decimal point if calibration was successful.
10. The **90-FLT** is now calibrated for Conductivity and is ready for use in this mode.

Ensure that the sensor is immersed at least as deeply as per the diagram in step 7 for all sample measurements.

4.5 Conductivity Calibration Notes

1. A Zero calibration should be performed at least monthly. In low conductivity applications (where a zero error is particularly significant), a zero calibration may have to be done weekly.
2. A Standard calibration should be performed at least weekly. Of course, more frequent calibration will result in greater confidence in results.
3. Conductivity and TDS calibration data is stored separately in memory. Ensure that the **90-FLT** has been correctly calibrated for the mode in which it will be used. The **90-FLT** does not require re-calibration when alternating between Conductivity and TDS modes, providing the instrument has been correctly calibrated for each mode on the k factor sensor to be used.
4. All calibration information is retained in memory when the **90-FLT** is switched off. This information can be recalled or printed later using the GLP function (see section 10).
5. The **90-FLT** displays the value of the standard to which it will attempt to calibrate. Ensure that the standard value displayed corresponds to the standard that you are using. Alter the Standards set-up if necessary (see section 4.2).
6. Calibration settings for k=0.1, k=1 and k=10 sensors are NOT stored separately.
The **90-FLT** requires re-calibration when a new k factor sensor is connected.

4.6 Conductivity Calibration Messages

1. If a Zero Calibration has been successfully performed, the **90-FLT** will display the following message...

```

0.00uS                25.0°C
Calibration OK, Zero=0.01uS

```

2. If a Standard Calibration has been successfully performed, the **90-FLT** will display the following message and the calculated k factor of the sensor. For example...

```

2.76mS                25.0°C
Calibration OK, k=0.99

```

3. If a Standard Calibration has failed, the **90-FLT** will display the following message and the calculated k factor of the sensor. For example...

```

Calibration Failure. Check STD=2760uS/cm
k=3.64, Exceeds Limit

```

Notes

1. The allowable k factor range is +/-25% of nominal. This range is ample to allow for correctly functioning Conductivity sensors. If calibration fails due to the k factor being outside these limits, then please consult the Troubleshooting guide (section 18.3) for possible remedies.

5. TDS Mode

5.1 Selecting TDS Mode

1. Select TDS Mode (Menu) → **F2:Mode** → **F4:TDS**).
2. The **90-FLT** now proceeds to TDS measurement mode. Note that a “*” is shown in place of the decimal point until a successful calibration has been performed (see section 5.4).

5.2 Setting the TDS calibration standard

The factory default for this item is 36.00 ppK. If this is satisfactory, go directly to section 5.3.

1. Select TDS Standard entry (Menu) → **F4:Setup** → **F1:Standards** → **F2:TDS**).

The following screen is now displayed...

```
TDS Standard:36.00ppK
Range 20 ppM to 500 ppK
```

2. Type in the value of the TDS standard that is to be used for calibration, including the decimal point. Use the ← key to make any corrections.
3. Press **Enter** to save the value of the standard solution.
Alternatively, press (Menu) to quit without changing the current setting.
4. The **90-FLT** will now ask you to enter the units for the TDS standard...

```
TDS Standard:36.00
Select Units   F1:ppM   F2:ppK
```

Press **F1** to set the TDS Standard as ppM (parts per Million).

Press **F2** to set the TDS Standard as ppK (parts per Thousand).

5. The TDS standard is now programmed for use at calibration.

5.3 Setting the TDS sensor k factor

The **90-FLT** automatically recognises a k=10 sensor. If a k=10 sensor is being used, go directly to section 5.4.

The **90-FLT** **does not** automatically recognise k=0.1 or k=1 sensors. When a k=0.1 or k=1 sensor is used, the **90-FLT** must be set to the correct k factor before use.

To select a k=0.1 or k=1 sensor...

1. Select k factor entry (Menu) → **F4:Setup** → **F4:k factor**).
2. The k factor entry screen is now displayed...

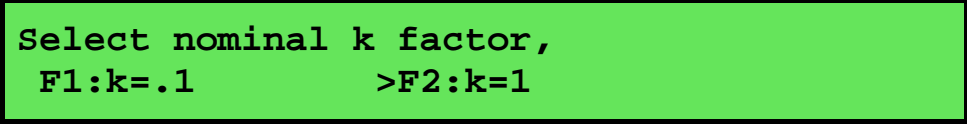

Select nominal k factor,
F1:k=.1 >F2:k=1

The arrow indicates the current selection.

Press (F1) if a k=0.1 sensor is being used.

Press (F2) if a k=1 sensor is being used.

Press (Menu) to quit without changing the current setting.

Notes

1. The manual k factor selection is kept in memory when the meter is switched off.
2. The manual k factor selection is reset to k=1 during initialisation.
3. The **90-FLT** will always automatically recognise a k=10 sensor, regardless of the manual k factor selection.
4. Calibration settings for k=0.1, k=1 and k=10 sensors are NOT stored separately.
The **90-FLT** requires re-calibration when a new k factor sensor is connected.

5.4 TDS Calibration

Before attempting a TDS calibration, ensure that the **90-FLT** has been set up correctly according to sections 5.1 to 5.3.

1. Plug the TDS sensor into the **Cond/Sal** socket.
2. Rinse the TDS sensor in distilled water. Shake off as much water as possible. Blot the outside of the sensor dry. **DO NOT BLOT THE ELECTRODE PLATES.**

Zero Calibration

3. Let the sensor dry in air.
4. Select TDS Calibration (Menu) → **F1:Calibrate** → **F2:TDS**).
5. The **90-FLT** will recognise the low TDS signal and attempt a Zero calibration. For example...

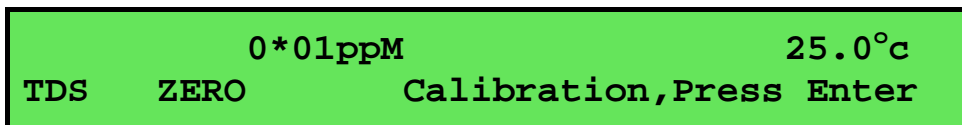

6. When the reading has stabilised at or near zero, press (Enter) to calibrate or (Menu) to quit. The “ * ” will not be removed after a zero calibration.

Standard Calibration

7. Place the TDS sensor into a sample of TDS standard. Ensure that it is immersed correctly, as per the diagram below.

DO NOT place the sensor directly into the bottle of standard. Discard the used sample of standard after use.

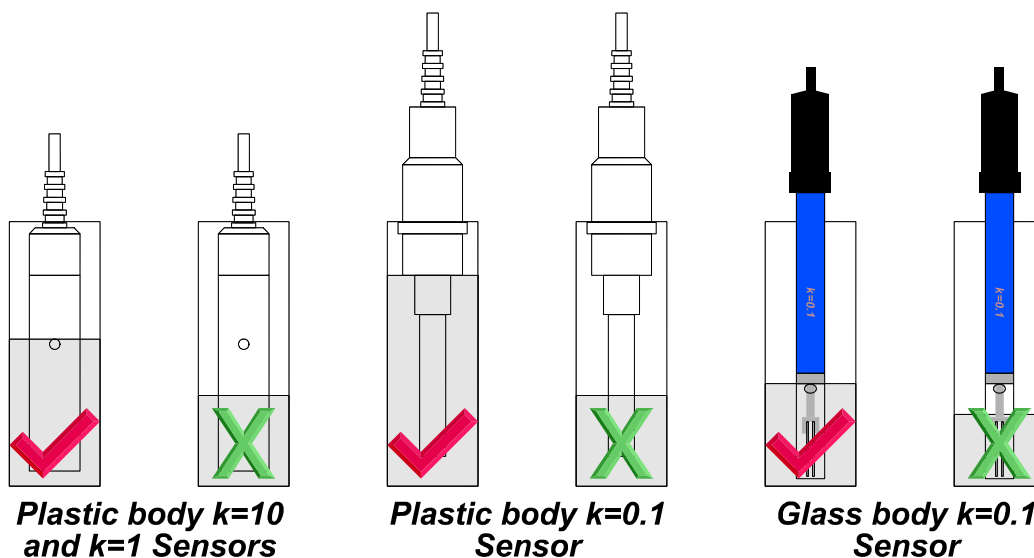

8. Select TDS Calibration (Menu) → **F1:Calibrate** → **F2:TDS**). The calibration screen will be displayed with the TDS standard to be used. For example...

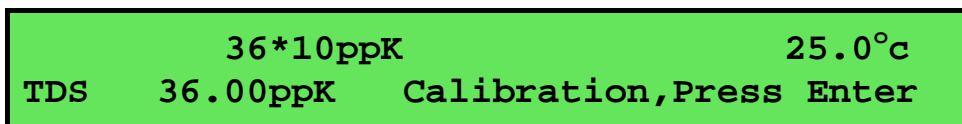

9. When the reading has stabilised, press (Enter) to calibrate. The “ * ” will now be replaced by a decimal point if calibration was successful.
10. The **90-FLT** is now calibrated for TDS and is ready for use in this mode.

Ensure that the sensor is immersed at least as deeply as per the diagram in step 7 for all sample measurements.

5.5 TDS Calibration Notes

1. A Zero calibration should be performed at least monthly. In low TDS applications (where a zero error is particularly significant), a zero calibration may have to be done weekly.
2. A Standard calibration should be performed at least weekly. Of course, more frequent calibration will result in greater confidence in results.
3. Conductivity and TDS calibration data is stored separately in memory. Ensure that the **90-FLT** has been correctly calibrated for the mode in which it will be used. The **90-FLT** does not require re-calibration when alternating between Conductivity and TDS modes, providing the instrument has been correctly calibrated for each mode on the k factor sensor to be used.
4. All calibration information is retained in memory when the **90-FLT** is switched off. This information can be recalled or printed later using the GLP function (see section 10).
5. The **90-FLT** displays the value of the standard to which it will attempt to calibrate. Ensure that the standard value displayed corresponds to the standard that you are using. Alter the Standards set-up if necessary (see section 5.2).
6. Calibration settings for k=0.1, k=1 and k=10 sensors are NOT stored separately.
The **90-FLT** requires re-calibration when a new k factor sensor is connected.

5.6 TDS Calibration Messages

1. If a Zero Calibration has been successfully performed, the **90-FLT** will display the following message...

```

0.00ppM                25.0°C
Calibration OK, Zero=0.01ppM

```

2. If a Standard Calibration has been successfully performed, the **90-FLT** will display the following message and the calculated k factor of the sensor. For example...

```

36.00ppK                25.0°C
Calibration OK, k=9.90

```

3. If a Standard Calibration has failed, the **90-FLT** will display the following message and the calculated k factor of the sensor. For example...

```

Calibrate Failure. Check STD=36.00ppK
k=15.0, Exceeds Limit

```

Notes

2. The allowable k factor range is +/-25% of nominal. This range is ample to allow for correctly functioning TDS sensors. If calibration fails due to the k factor being outside these limits, then please consult the Troubleshooting guide (section 18.3) for possible remedies.

6. pH Mode

6.1 Selecting the pH Buffer Set

The **90-FLT** can be programmed to automatically recognise any of the following buffer sets during pH calibration. All pH values listed below are at 25 °C.

1. pH4.00, pH6.88, pH9.22
2. pH4.00, pH6.88, pH10.06
3. pH4.00, pH7.00, pH9.22
4. pH4.00, pH7.00, pH10.06.

To select the pH buffer set for automatic recognition...

1. Select the pH Buffer set-up menu.

(Menu) → **F4:Setup** → **F1:Standards** → **F3:pH Buffers**).

2. The primary buffer selection menu is now displayed...

```
Select Primary Buffer
>F1:6.88pH      F2:7.00pH
```

The arrow indicates the current selection.

Press (F1) to select pH6.88 as the Primary Buffer.

Press (F2) to select pH7.00 as the Primary Buffer.

Press (Menu) to quit without changing the current setting.

3. The secondary buffers selection menu is now displayed...

```
Select Secondary Buffers
>F1:4.00/9.22pH      F2:4.00/10.06pH
```

The arrow indicates the current selection.

Press (F1) to select pH4.00 and pH9.22 as the Secondary Buffers.

Press (F2) to select pH4.00 and pH10.06 as the Secondary Buffers.

Press (Menu) to quit without changing the current setting.

Notes

1. The selected buffer set is kept in memory when the meter is switched off.
2. The buffers are re-set to pH4.00, pH6.88 and pH9.23 during initialisation.
3. pH6.88 buffer is a DIN 19266 and NBS Primary-standard pH solution. Its use as the primary buffer is highly recommended for the most accurate possible results. If pH7.00 buffer is used, ensure that it is manufactured to at least 0.01pH accuracy. pH7.00 buffer has a buffer capacity less than half that of pH6.88 buffer and is therefore much less stable.
4. pH9.23 and pH10.06 buffers are highly unstable. Avoid using these buffers if possible. Discard immediately after use.
5. If you wish to use a pH buffer other than one of those listed above, its value can be keyed in during calibration. Make sure that you have pH versus Temperature data for the buffer.

6.2 pH Calibration

1. Plug the pH sensor into the **pH** socket and the Conductivity/TDS or Temperature sensor into the **COND/SAL** socket.
2. Ensure that temperature has already been calibrated (see section 9.1) or manually set (see section 9.4. NOTE: The decimal point in the Temperature reading is shown by a “ * ”, when the temperature readout is not calibrated).
3. Remove the wetting cap from the pH sensor. Rinse the pH and Conductivity/TDS or Temperature sensors in distilled water and blot them dry.
4. Ensure that the primary and secondary buffers to be used have been correctly selected for automatic buffer recognition. See section 6.1.
5. Place both electrodes into a small sample of primary buffer (pH6.88 or 7.00), so that the bulb and reference junction are both covered as per the diagram below.

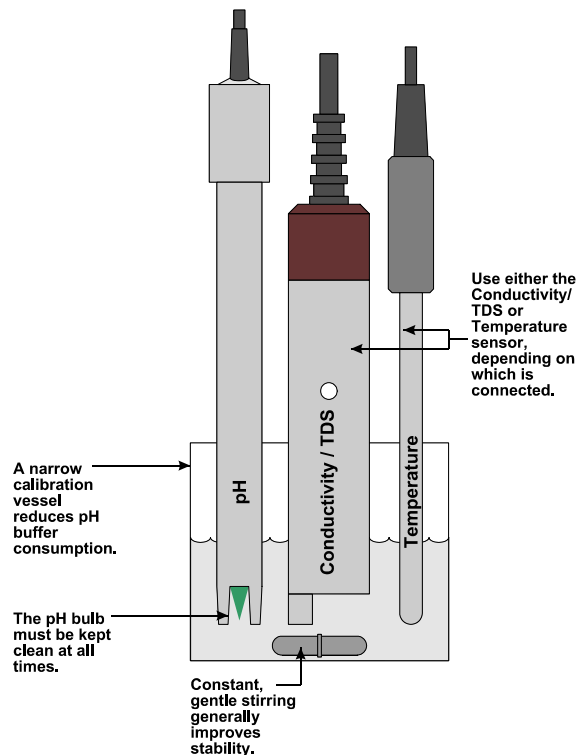

DO NOT place the electrodes directly into the buffer bottle.

6. Select pH calibration (Menu) → **F1:Calibrate** → **F3:pH**).

The display should now look something like this...

```

6*85pH      Buffer=6.87      25.0°C
Press ENTER to Calibrate, or Edit Buffer.
  
```

The current pH reading is shown on the left. Note the “ * ”, indicating that pH is currently not calibrated. Wait for this reading to stabilise before attempting to calibrate the **90-FLT**.

The buffer that the **90-FLT** has attempted to recognise is also displayed with the correct value at the current temperature.

Press (Enter) to calibrate to the displayed buffer.

Otherwise, enter an alternative buffer using the Numeric Keypad, and then press (Enter).

The meter is now 1 point calibrated. Note that the “ * ” will not be removed until a full 2 point calibration has been performed.

7. Rinse the pH and Conductivity/TDS or Temperature sensors in distilled water and blot them dry.
8. Place both sensors into a small sample of secondary buffer (pH4.00, 9.23 or 10.06), so that the bulb and reference junction are both covered as per the diagram in step 5.

DO NOT place the electrodes directly into the buffer bottle.

NOTE: pH9.23 and pH10.06 buffers are highly unstable. Avoid using these buffers if possible. Discard immediately after use.

9. Select pH calibration (Menu → **F1:Calibrate** → **F3:pH**).

The display should now look similar to the example shown in step 6. Note that the **90-FLT** has automatically recognised the second buffer.

Wait for the displayed reading to stabilise before attempting to calibrate the **90-FLT**.

Press Enter to calibrate to the displayed buffer.

Otherwise, enter an alternative buffer using the Numeric Keypad, and then press Enter .

10. The **90-FLT** is now pH calibrated and is ready for use in this mode. Discard the used samples of buffer.

Rinse the pH and Conductivity/TDS or Temperature sensors in distilled water and blot them dry before placing them into unknown samples.

6.3 pH Calibration Notes

1. A 1-point calibration should be performed at least weekly. In applications where the electrode junction can become blocked such as dairy products, mining slurries etc, a 1-point calibration may have to be done daily.
2. A full 2-point calibration should be performed at least monthly. Of course, more frequent calibration will result in greater confidence in results.
3. All calibration information is retained in memory when the **90-FLT** is switched off, even when the power supply is removed. This information can be recalled or printed later using the GLP function (see section 10).

6.4 pH Calibration Messages

1. If a 1-point calibration has been successfully performed, the **90-FLT** will display the following message and the asymmetry of the electrode. Note that the slope value from the last calibration is also shown.

```
Asymmetry Calibration Successful
+0.10pH Asym      100% Slope
```

2. If a 1-point calibration has failed, the **90-FLT** will display the following message and the failed asymmetry value of the electrode.

```
Calibrate Failed, 1.2pH Asymmetry
Repeat Cal. or Initialise Calibration
```

3. If a 2-point calibration has been successfully performed, the **90-FLT** will display the following message and the asymmetry and slope of the electrode.

```
Slope & Asymmetry Calibration Successful
+0.10pH Asym      99.0% Slope
```

4. If a 2-point calibration has failed, the **90-FLT** will display the following message and the failed slope value of the electrode.

```
Calibrate Failed, 80% Slope
Repeat Cal. or Initialise Calibration
```

5. The **90-FLT** has an allowable Asymmetry range of -1.00 to $+1.00$ pH. The allowable Slope range is 85.0 to 105.0 %. If calibration fails due to either the Asymmetry or the Slope being outside these limits, then please consult the Troubleshooting guide (section 18.4) for possible remedies.

7. Millivolt Mode

7.1 Millivolt Measurements

The millivolt section of the **90-FLT** is factory calibrated. There is no user-calibration facility for this mode.

Temperature compensation is not applicable in Millivolt mode.

Simply plug the Redox sensor into the **mV** socket. Ensure that the platinum tip and reference junction are both covered, as per the diagram below.

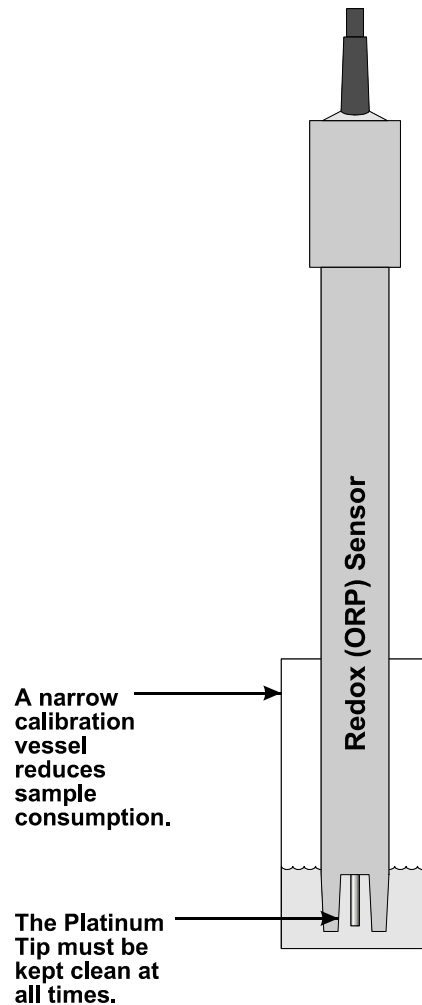

8. Turbidity Mode

8.1 Fitting the Cable to the Sensor



1. Push the cable plug into the socket in the rear of the Turbidity Sensor. Be sure to align the pins of the plug and socket before inserting.
2. Screw on the retaining nut. Finger tighten only, as over tightening may cause damage to the sensor body.

DO NOT USE A SPANNER.

8.2 Fitting the Protector to the Sensor

The extra slide-on plastic protector (part no 125189) is an optional extra. To fit the protector...

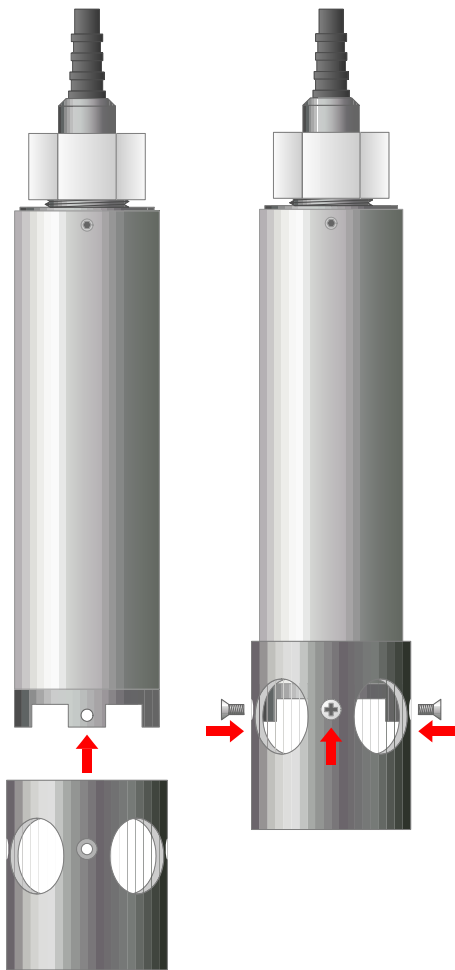

1. Slide the protector onto the Turbidity Sensor until the countersunk holes line up with the tapped holes in the sensor's four feet.
2. Screw in the 4 supplied countersunk 1/8 BSW x 1/4" stainless steel screws. Do not over tighten, as the sensor feet may be damaged.

DO NOT USE AN ELECTRIC SCREWDRIVER.

8.3 Setting the Turbidity calibration standard

The factory defaults for this item are 90 NTU for the low range and 900 NTU for the high range. If these are satisfactory, go directly to section 8.4.

In order to calibrate the **90-FLT** it is first necessary to enter the value of the Turbidity standard which is to be used for calibration. To enter the Turbidity standard value...

1. Select the Turbidity Standards menu :

(Menu) → **F4:Setup** → **F1:Standards** → **F4:Turbidity**).

2. The Turbidity standard for the Low Turbidity mode can entered, for example...

**Enter Low Turbidity Standard : 90.0 NTU
Range 30 to 180 NTU**

Type in the value of the Turbidity standard that is to be used for calibration. Use the \ominus key to make any corrections. The allowable range is 30 to 180 NTU.

Press (Enter) to save the value of the standard solution.

Press (Menu) to retain the current setting and move to the high range Turbidity standard.

3. The Turbidity standard for the High Turbidity mode can now be entered, for example...

**Enter High Turbidity Standard : 900 NTU
Range 300 to 2000 NTU**

Type in the value of the Turbidity standard that is to be used for calibration. Use the \ominus key to make any corrections. The allowable range is 300 to 2000 NTU.

Press (Enter) to save the value of the standard solution.

Press (Menu) to retain the current setting and exit to the Standards menu.

4. The Turbidity standard is now programmed for use at calibration.

8.4 Turbidity Calibration

Before attempting a Turbidity calibration, ensure that the Turbidity standard has been entered correctly (see section 8.3).

1. Plug the Turbidity sensor into the **TURBIDITY** socket.
2. Rinse the Turbidity sensor in distilled water. Shake off as much water as possible. Blot the outside of the sensor dry.

Zero Calibration

3. Place the Turbidity sensor into a sample of fresh Distilled water (NOT the rinse water used in step 3, above. If possible, the vessel should have black or dark floor and walls to avoid reflection affecting the reading. Ensure that there is a minimum of 30mm clearance to the floor and walls of the vessel, as per the following diagram...

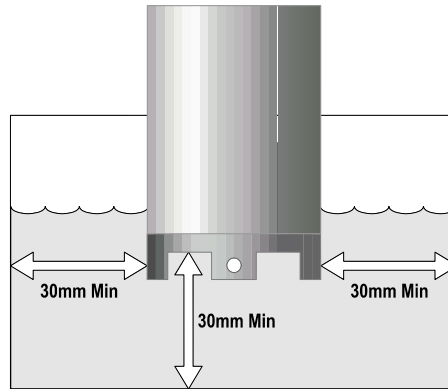

Take care to ensure that there are no bubbles trapped on the underside of the sensor. Bubbles can interfere with Turbidity measurements. Gently stir the sample or the sensor to dislodge any bubbles.

4. Select Turbidity Calibration :
 (Menu) → **F1:Calibrate** → **F4:Turbidity**).

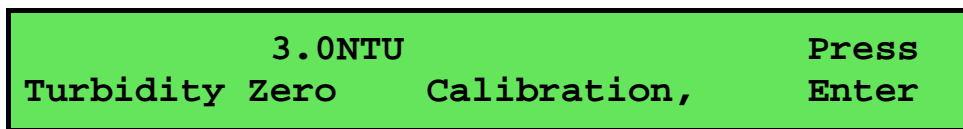

5. When the reading has stabilised at or near zero, press (Enter) to calibrate or (Menu) to quit. The “ * ” will not be removed after a zero calibration.

Span Calibration

6. Place the Turbidity sensor into a sample of Turbidity standard. If possible, the vessel should have black or dark floor and walls to avoid reflection affecting the reading. Ensure that it is immersed correctly, as per the diagram in step 4, above.

7. Select Span Calibration (Menu) → **F1:Calibrate** → **F4:Turbidity**). The calibration screen will be displayed with the Turbidity standard to be used. For example...

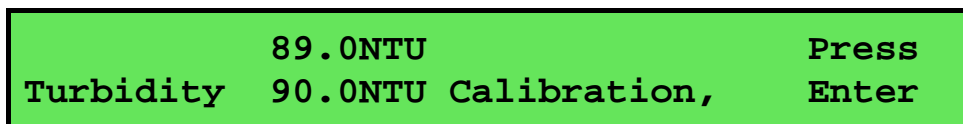

8. When the reading has stabilised, press (Enter) to calibrate. The “ * ” will now be replaced by a decimal point if calibration was successful.
9. The **90-FLT** is now calibrated for Turbidity and is ready for use in this mode. Ensure that the Turbidity readout has been calibrated on the range on which it will be used.

Ensure that the sensor is immersed with at least the same clearance as per the diagram in step 4 for all sample measurements.

8.5 Turbidity Calibration Notes

1. Calibration information for the Low and High Turbidity modes is stored separately. Ensure that the sensor has been Zero and Span calibrated in the required mode.
2. Calibration information is stored in the Turbidity sensor. It is therefore possible to change sensors without recalibrating, providing the new sensor has been calibrated in the required mode.
3. Frequency of calibration depends on the significance of the results. The Turbidity sensor uses precision optics and electronics, minimising the need to recalibrate frequently.
4. All calibration information can be recalled or printed using the GLP function (see section 10).
5. Always ensure that the value of the Turbidity standard displayed during calibration corresponds to the standard that is actually being used.

8.6 Calibration Messages

1. When a Zero Turbidity calibration has been successfully performed, the **90-FLT** will display the following message and the zero value of the sensor. For example...

```

0*NTU      Low Zero= 0.1NTU
Calibrate OK,      High Zero= 1.NTU

```

(The “ * ” is not removed until a standard calibration has been successfully performed.)

2. When a span calibration has been successfully performed, the **90-FLT** will display the following message and the span value of the sensor.

```

90.0NTU
Calibrate OK Span=100.1%

```

3. If a span calibration has failed, the **90-FLT** will display the following message and the failed span value of the sensor.

```

252*NTU
Calibrate Failed, Span=70.0%

```

4. The **90-FLT** has an allowable span range of 75.0 to 133.0 %. If calibration fails due to the Span being outside these limits, then please consult the Troubleshooting guide (section 18.5) for possible remedies.

9. Temperature Mode

The temperature readout must be calibrated before attempting pH or ppM Dissolved Oxygen calibration and measurements.

The decimal point is replaced by a “*” if the reading is not calibrated.

The **90-FLT** is able to take Temperature readings from the Conductivity/TDS sensor or a separate Temperature probe. Only one or the other can be connected at any one time. Ensure that the **90-FLT** has been calibrated on the correct sensor.

9.1 Temperature Calibration

1. Plug Conductivity/TDS or separate Temperature sensor into the **Cond/Sal** socket.
2. Place the sensor into a beaker of room temperature water, alongside a good quality mercury thermometer. Stir the sensor and the thermometer gently to ensure an even temperature throughout the beaker.
3. Select Temperature Calibration (Menu → **F1:Calibrate** → **F5:Temperature**).

The Temperature Calibration screen is now displayed...

```
Enter Actual Temperature : _      24.0°C
Temperature Calibration      Menu Quits
```

4. The current reading from the sensor is displayed on the far right of the top line.
When this reading has stabilised, use the Numeric Keypad to enter the same temperature as measured by the mercury thermometer.
5. Press the Enter key to calibrate the temperature readout.

Alternatively, press the Menu key to abort temperature calibration.

The **90-FLT** is now 1 point temperature calibrated. This will provide precision to approximately ± 0.5 °C. The following screen is displayed...

```
1 Point Calibration OK,      Offset=0.1°C
Press Enter for Span Cal. or Menu Quits
```

Press Menu if ± 0.5 °C is adequate for your application. The **90-FLT** will now return to normal measurement mode and the “*” in the Temperature readout will have been replaced by a decimal point.

Press Enter to go on to a second point calibration if a higher degree of precision is required.

7. When a second point calibration is being performed, the **90-FLT** will now display the second calibration screen..

```
Enter Actual Temperature : _      36.0°C
15.0 > Temp > 35.0      Menu Quits
```

Please note that the sensor must now be placed into a container of water that is at least 10 °C higher or lower than the first calibration point.

An insulated container with around 1 Litre or more of water will provide a stable environment to do the second point Temperature calibration. The Temperature of the water in a small, uninsulated container will change too rapidly, making a successful second point calibration virtually impossible.

8. The current reading from the sensor is displayed on the far right of the top line.
When this reading has stabilised, use the Numeric Keypad to enter the same temperature as measured by the mercury thermometer.
9. Press the **Enter** key to calibrate the temperature readout.
Alternatively, press the **Menu** key to abort the second point temperature calibration. The first point calibration settings will still be preserved.
10. The **90-FLT** is now Temperature calibrated and is ready for use in this mode.
The full ± 0.2 °C accuracy specification will apply after a successful 2 point calibration.

9.2 Temperature Calibration Notes

1. Temperature calibration information is retained in memory when the **90-FLT** is switched off. This information can be recalled later using the GLP function (see section 10).
2. Temperature does not need to be re-calibrated unless the Conductivity/TDS or Temperature sensor is replaced or the meter is initialised.

9.3 Calibration Messages

5. If a 1 point temperature calibration has been successfully performed, the **90-FLT** will display the following message and the offset value of the sensor. The bottom line appears after 3 seconds.

```
1 Point Calibration OK,      Offset=0.1°C
Press Enter for Span Cal. or Menu Quits
```

6. If a 1 point temperature calibration has failed, the **90-FLT** will display the following message and the failed offset value of the sensor.

```
1 Point Calibration Failed, Offset=16.0°C
```

7. The **90-FLT** has an allowable Offset range of -15.0 to +15.0 °C. If calibration fails due to the Offset being outside these limits, then please consult the Troubleshooting guide (section 18.5) for possible remedies.
8. If a 2 point temperature calibration has been successfully performed, the **90-FLT** will display the following message and the span value of the sensor.

```
2 Point Calibration OK,      Span=101.0%
```

9. If a 2 point temperature calibration has failed, the **90-FLT** will display the following message and the failed span value of the sensor.

```
2 Point Calibration Failed, Span=200.0%
```

10. The **90-FLT** has an allowable span range of 93.0 to 107.0 %. If calibration fails due to the Span being outside these limits, then please consult the Troubleshooting guide (section 18.5) for possible remedies.

9.4 Manual Temperature Setting

If a Conductivity/TDS or Temperature sensor is not connected, the temperature of the sample solution must be set manually for accurate ppm Dissolved Oxygen or pH measurements. A separate thermometer will be required for this. Temperature compensation is not applicable for Millivolt mode.

1. Measure the temperature of the sample.
2. Select Temperature Calibration (Menu → **F1:Calibrate** → **F2:Temperature**).
3. The current temperature setting is now displayed. For example...

```
Enter Manual Temperature : 25.0 °C
                          Menu Quits
```

4. Enter the temperature of the sample, using the Numeric Keypad.
Press Enter to save the new value.
Alternatively, press Menu to quit and retain the current setting.
5. When returning to normal measurement mode, note the “M” in the temperature readout, indicating that Manual Temperature Compensation is in use. For example...

```
10.00ppM  2.76mS  7.00pH  360.NTU  25.0°CM
  Oxy      Cond           18/10 12:00:00
```

10. Good Laboratory Practices (GLP)

The **90-FLT** keeps a record of the date and time of the last calibrations for all parameters as part of GLP guidelines.

10.1 To recall GLP information on the display

1. Select the GLP menu (Menu) → **F4:Setup** → **F2:GLP**).
2. Select **F1:Recall** from the menu.
3. The instrument model, firmware version number, and instrument serial number are displayed, along with a prompt describing how to scroll through the GLP information.

```
90FLm      V9.0 T1234 @ 18/10/06 14:00
                                     F4:Next
```

The “m” after the model name is displayed when the Dissolved Oxygen stirrer is enabled.

5. Press the (F4) key to sequentially scroll through the GLP information for all parameters. Press the (F2) key to scroll back to previous data. The sequence of information displayed is shown below. Press (Menu) to abort at any time.

GLP Display sequence...

```
90FLm      V9.0 T1234 @ 18/10/06 14:00
Turbidity V1.0 T4321                                     F4:Next
```

↑(F2) ↓(F4)

```
Oxygen Zero=0.1%      18/10/06 12:00
Oxygen Calibrated     F2:Back F4:Next
```

↑(F2) ↓(F4)

```
Oxygen Span=100.0%   18/10/06 12:10
Oxygen Calibrated     F2:Back F4:Next
```

↑(F2) ↓(F4)

```
Cond. Zero=0.01uS    18/10/06 12:20
Cond Calibrated      F2:Back F4:Next
```

↑(F2) ↓(F4)

```
Cond. k=10.1         18/10/06 12:30
Cond Calibrated      F2:Back F4:Next
```

↑(F2) ↓(F4)

```
TDS Zero=0.01ppM    18/10/06 12:20
TDS Calibrated      F2:Back F4:Next
```

↑(F2) ↓(F4)

Continued over the page...

GLP Display sequence, continued...

TDS k=10.1 18/10/06 12:40
TDS Calibrated F2:Back F4:Next

↑ F2 ↓ F4

pH Asymmetry=0.10pH 18/10/06 12:50
pH Calibrated F2:Back F4:Next

↑ F2 ↓ F4

pH Slope= 99.0% 18/10/06 13:00
pH Calibrated F2:Back F4:Next

↑ F2 ↓ F4

Turbidity Lo Zero=0.1NTU 18/10/06 13:10
Turbidity Calibrated F2:Back F4:Next

↑ F2 ↓ F4

Turbidity Lo Span=100.1% 18/10/06 13:20
Turbidity Calibrated F2:Back F4:Next

↑ F2 ↓ F4

Turbidity Hi Zero=1NTU 18/10/06 13:10
Turbidity Calibrated F2:Back F4:Next

↑ F2 ↓ F4

Turbidity Hi Span=100.1% 18/10/06 13:20
Turbidity Calibrated F2:Back F4:Next

↑ F2 ↓ F4

Temperature Offset=1.0°C 18/10/06 13:30
Temp Probe Calibrated F2:Back F4:Next

↑ F2 ↓ F4

Temperature Span=100.0% 18/10/06 13:40
Temp Probe Calibrated F2:Back F4:Ends

10.2 Failed Calibration

If calibration has failed, the GLP function will reset the date and time for the failed parameter to zero. The **90-FLT** still shows the results for the last successful calibration, as shown in the following example of a failed pH calibration....

```
pH Asymmetry= 0.10pH      00/00/00 00:00
pH Un-Calibrated      F2:Back F4:Next
```

10.3 Printing GLP Information to the RS232 Port

The GLP information stored in the instrument's memory can be sent to a printer or PC via the RS232 port.

1. Switch the meter on.
2. Connect one end of the RS232 cable to the **Charger** socket of the **90-FLT**. The battery charger, optional battery adaptor, or optional solar panel may be connected to the in-line socket on the RS232 cable, if required.
3. Connect the other end of the RS232 cable to an RS232 Printer, or to the COM1 or COM2 ports of a PC.
4. Send the GLP information to the RS232 port:

 → **F4:Setup** → **F2:GLP** → **F3:Print**

The message "**Printing GLP Data**" is displayed while sending the data to the RS232 port.

5. The GLP information is sent to the RS232 port in formatted ASCII text. For example...

```
90FLT V9.0 T1234 Turbidity Probe V1.0 T4321 @ 18/10/2006 14:00
Oxygen          Zero=          0.1%      @ 18/10/2006 12:00
Oxygen          Span=          100.0%    @ 18/10/2006 12:10
Conductivity    Zero=          0.01uS   @ 18/10/2006 12:20
Conductivity    k=             1.01     @ 18/10/2006 12:30
TDS             Zero=          0.01ppM   @ 18/10/2006 12:20
TDS             k=             1.01     @ 18/10/2006 12:40
pH              Asy=           0.10pH   @ 18/10/2006 12:50
pH              Slope=          99.0%    @ 18/10/2006 13:00
Turbidity Low   Zero=          0.1NTU   @ 18/10/2006 13:10
Turbidity Low   Span=          100.1%    @ 18/10/2006 13:20
Turbidity High  Zero=          0.0NTU   @ 18/10/2006 13:30
Turbidity High  Span=          100.1%    @ 18/10/2006 13:40
Temperature     Offset=         1.0oC    @ 18/10/2006 13:50
Temperature     Span=          100.0%    @ 18/10/2006 14:00
Ends
```

10.4 Instrument Serial Number

In case the serial number that is fitted to the rear of the **90-FLT** is removed or becomes illegible, it is also available on the **90-FLT** display.

1. The serial number is displayed at turn-on, for example...

```
90FLTm V9.0 T1234 (c) 2004 TPS Pty Ltd  
Oxygen, Conductivity, TDS, pH, Turbidity
```

The “m” after the model name is displayed when the Dissolved Oxygen stirrer is enabled.

2. The serial number is displayed when recalling the GLP information (section 10.1).
3. The serial number is included on the print-out of GLP information (section 10.3).
4. The GLP information can be downloaded to a PC using the optional Windows® software (part number 130086).

10.5 Additional GLP Features

Another GLP requirement is to record the date and time of every reading. The **90-FLT** does this for you when readings are recorded either with the Manual Datalogging function (section 11.2) or the Automatic Datalogging function (section 11.3).

11. Datalogging

11.1 Setting the A & B Data Input Function

The A & B Data Input function allows the operator to enter extra numerical data whenever datalogging manually. The A & B Data Input function can also be set for any one of the following...

- “A” as Pond number with no extra “B” data input.
- “A” as Pond number with extra “B” data input.
- “A” as data input with no extra “B” data input.
- “A” and “B” both as data input.
- A & B Data Input Function switched OFF.

The Logger memory must be erased before changing the A & Data Input setting.

To set the A & B Data Input function...

1. Select the A & B setup menu (Menu) → **F4:Setup** → **F3:Set AB**). The **90-FLT** will prompt you to erase the Logger before proceeding, if any data is stored in memory.

```
SET  F1:A=Pond,No B  F2:A=Pond,B=Data
A/B  F3:A=Data,No B  F3:A&B=Data >F5:OFF
```

The arrow indicates the current selection.

2. Press (F1) to set “A” as Pond number with no extra “B” data input.
Press (F2) to set “A” as Pond number with extra “B” data input.
Press (F3) to set “A” as data input with no extra “B” data input.
Press (F4) to set “A” and “B” both as data input.
Press (F5) to switch the A & B Data Input function OFF.
Press (Menu) to quit and retain the current setting.
3. The A & B Data Input function is now set and is ready for use during Manual Datalogging.

11.2 Manually Recording Readings into the Logger

11.2.1 When A & B Data Input has been set to OFF

1. Press (Store) in normal display mode. The display should now look like this...

```
10.00ppM  2.76mS   7.00pH   360.NTU  25.0°C
Log#1,    <Enter>   1000mV  18/10  12:00:00
```

2. Press (Enter) to record all parameters plus Date and Time into the Logger memory. This will be labelled as reading number 1.
Alternatively, press (Menu) to quit without recording the reading.
3. Repeat steps 1 & 2 as often as required. The maximum number of readings that can be stored in the Logger with the A & B Data Input function switched OFF is 6520.

11.2.2 When A is set to Pond, with no extra B data

1. Press **(Store)** in normal display mode. The display should now look like this...

```
10.00ppM  2.76mS  7.00pH  360.NTU  25.0°C
Log#1,    Pond#1  1000mV  18/10  12:00:00
```

2. Use the numeric keypad to key in the Pond number, then press **(Enter)** to record all parameters, Date, Time and the Pond number into the Logger memory. This will be labelled as reading number 1.

Alternatively, press **(Menu)** to quit without recording the reading.

3. Repeat steps 1 & 2 as often as required.

The Pond number will automatically increment by one from the last recorded reading.

The maximum number of readings that can be stored in the Logger with this A & B Data Input setting is 5440.

11.2.3 When A is set to Pond, and B is set to data

1. Press **(Store)** in normal display mode. The display should now look like this...

```
10.00ppM  2.76mS  7.00pH  360.NTU  25.0°C
Log#1,    Pond#1  1000mV  18/10  12:00:00
```

2. Use the numeric keypad to key in the Pond number, then press **(Enter)** to record all parameters, Date, Time and the Pond number into the Logger memory. This will be labelled as reading number 1.

Alternatively, press **(Menu)** to quit without recording the reading.

3. The **90-FLT** now proceeds to the B data entry screen...

```
Data Recorded, Now Input B or Press Menu
Enter Data B:0
```

Use the numeric keypad to key in up to four characters for the “B” data item. The decimal point is available. Press **(Enter)** to record the “B” data item, or press **(Menu)** to quit. Quitting at this point records a Zero as the “B” data item.

4. Repeat steps 1 to 3 as often as required.

The Pond number will automatically increment by one from the last recorded reading.

The maximum number of readings that can be stored in the Logger with this A & B Data Input setting is 5440.

11.2.4 When A is set to Data with no B data

1. Press **(Store)** in normal display mode. The display should now look like this...

```
10.00ppM  2.76mS  7.00pH  360.NTU  25.0°C
Log#1,    <Enter>  1000mV  18/10  12:00:00
```

2. Press **(Enter)** to record all parameters, plus Date and Time into the Logger memory. This will be labelled as reading number 1.

Alternatively, press **(Menu)** to quit without recording the reading.

3. The **90-FLT** now proceeds to the A data entry screen...

```
Enter Data A:0
Data Recorded, Now Input A or Press Menu
```

Use the numeric keypad to key in up to four characters for the “A” data item. The decimal point is available. Press **(Enter)** to record the “A” data item, or press **(Menu)** to quit. Quitting at this point records a Zero as the “A” data item.

4. Repeat steps 1 to 3 as often as required.

The maximum number of readings that can be stored in the Logger with this A & B Data Input setting is 5440.

11.2.5 When A and B are both set to Data

1. Press **(Store)** in normal display mode. The display should now look like this...

```
10.00ppM  2.76mS  7.00pH  360.NTU  25.0°C
Log#1,    <Enter>  1000mV  18/10  12:00:00
```

2. Press **(Enter)** to record all parameters, plus Date and Time into the Logger memory. This will be labelled as reading number 1.

Alternatively, press **(Menu)** to quit without recording the reading.

3. The **90-FLT** now proceeds to the A data entry screen...

```
Enter Data A:0
Data Recorded, Now Input A or Press Menu
```

Use the numeric keypad to key in up to four characters for the “A” data item. The decimal point is available. Press **(Enter)** to record the “A” data item, or press **(Menu)** to quit. Quitting at this point records Zero’s as the “A” and “B” data items.

4. The **90-FLT** now proceeds to the B data entry screen...

```
Enter Data A:1234
Enter Data B:0
```

Use the numeric keypad to key in up to four characters for the “B” data item. The decimal point is available. Press **(Enter)** to record the “B” data item, or press **(Menu)** to quit. Quitting at this point records a Zero as “B” data item.

5. Repeat steps 1 to 4 as often as required. The maximum number of readings that can be stored in the Logger with this A & B Data Input setting is 5440.

11.3 Automatic Datalogging

The **90-FLT** can automatically log records into the Logger. There are three automatic datalogging modes to choose from...

1. Rate Per Day
 - Logs from 1 to 288 readings per day, evenly spaced throughout each 24 hour period.
 - Unit is dormant between readings and “wakes up” when a reading is due.
 - Dissolved Oxygen stirrer is switched on for 40 seconds before each reading is logged (if Dissolved Oxygen stirrer output is enabled).
 - Unit continues to log until automatic datalogging is disabled, or until the memory is full.
2. Time of Day
 - Logs at up to 12 discrete times of the day, which can be unevenly spaced throughout each 24 hour period.
 - Unit is dormant between readings and “wakes up” when a reading is due.
 - Dissolved Oxygen stirrer is switched on for 40 seconds before each reading is logged (if Dissolved Oxygen stirrer output is enabled).
 - Unit continues to log until automatic datalogging is disabled, or until the memory is full.
3. Sampling Period and Duration
 - Logs a reading every 1 to 300 seconds for a duration of 1 to 720 minutes.
 - Duration can be set to log continuously until the memory is full.
 - Unit is turned on continuously in this logging mode.
 - Dissolved Oxygen stirrer is switched on continuously in this logging mode (if Dissolved Oxygen stirrer output is enabled).

The automatic datalogging parameters of the **90-FLT** must first be programmed, then logging can be started and stopped as required.

11.3.1 Rate per Day Datalogging

Programming Rate per Day Datalogging

1. Select the Logger Program menu (Menu) → **F3:Logger F5:Program**)
2. Select **F1:Rate per Day** from the menu.

The display should now look similar to that shown below. The current Rate per Day is displayed...

Number of Readings per Day : 24

3. Use the Numeric Keypad to set the number of readings per day which the **90-FLT** will automatically log into memory. This can be set from 1 to 288 (i.e. 1 reading every 24 hours to 1 reading every 5 minutes).
Press (Enter) to save the Rate per Day.
Press (Menu) to quit without changing the current setting.
4. The Rate per Day datalogging is now programmed, and can be started and stopped as required.

Notes

1. The **90-FLT** distributes the number of readings evenly throughout a 24 hour clock cycle, regardless of what time automatic logging is started and stopped. For example, if the **90-FLT** is programmed to log 4 readings per day, they will be logged at 24:00, 6:00, 12:00 and 18:00 o'clock.

Starting and Stopping Rate per Day Datalogging

Starting Rate per Day datalogging is a two step process...

1. Select the Logger menu (Menu) → **F3:Logger**)
Select **F4:Start** from the menu.
2. Switch the **90-FLT** OFF.
This step is essential, as the Rate per Day datalogging is only enabled when the **90-FLT** is switched OFF.

Stopping Rate per Day datalogging is a one step process...

1. Select the Logger menu (Menu) → **F3:Logger**)
Select **F4:Stop** from the menu.

Notes



1. The **90-FLT** remains dormant between readings and only switches itself ON when a reading is due.
2. If the Dissolved Oxygen stirrer is enabled, it is switched on for 40 seconds before the reading is recorded.
3. The **90-FLT** is switched on 3 minutes before the next reading is due to ensure that the Dissolved Oxygen sensor is fully polarised. The unit will therefore not automatically log any readings for at least 3 minutes after it has been switched OFF, even if a reading is due during that time.

11.3.2 Time of Day Datalogging

Programming Time of Day Datalogging

1. Select the Logger Program menu ( → **F3:Logger F5:Program**)
2. Select **F2:Time of Day** from the menu.
The display should now look similar to that shown below. Any currently programmed times are displayed...

Log	00:00	00:00	00:00	00:00	00:00	00:00
Time	00:00	00:00	00:00	00:00	00:00	00:00

3. Use the Numeric Keypad to set the first time of the day at which the **90-FLT** will automatically log into memory.
4. Press  to move to the next time of the day.
5. Repeat steps 7 and 8 to enter up to 12 times of the day. The times do not need to be evenly spread throughout the day. Times must be entered in 24 hour clock format.
6. Press  to save the programmed times of the day and quit.
7. The Time of Day datalogging is now programmed, and can be started and stopped as required.

Notes

1. For 12:00 o'clock midnight, enter the time as “**24:00**”.
2. The times of the day do not need to be entered in chronological order. The **90-FLT** will sort them after pressing .

Starting and Stopping Time of Day Datalogging

Starting Time of Day datalogging is a two step process...

1. Select the Logger menu ( → **F3:Logger**)
Select **F4:Start** from the menu.
2. Switch the **90-FLT** OFF.

This step is essential, as the Time of Day datalogging is only enabled when the **90-FLT** is switched OFF.

Stopping Time of Day datalogging is a one step process.

1. Select the Logger menu ( → **F3:Logger**)
Select **F4:Stop** from the menu.

Notes

1. The **90-FLT** remains dormant between readings and only switches itself ON when a reading is due.
2. If the Dissolved Oxygen stirrer is enabled it is switched on for 40 seconds before the reading is recorded.
3. The **90-FLT** is switched on 3 minutes before the next reading is due to ensure that the Dissolved Oxygen sensor is fully polarised. The unit will therefore not automatically log any readings for at least 3 minutes after it has been switched OFF, even if a reading is due during that time.

11.3.3 Sampling Period and Duration Datalogging

Programming Sampling Period and Duration Datalogging

1. Select the Logger Program menu (Menu) → **F3:Logger F5:Program**)
2. Select **F3:Sampling Period and Duration** from the menu.
3. The **90-FLT** now prompts you to enter the sampling period in seconds. The current sampling period is displayed...

Enter Sampling Period (secs) : 5

Use the Numeric Keypad to set the **90-FLT** to log a reading every 1 to 300 seconds.

Press (Enter) to save the new sampling period and move to setting the duration.

Press (Menu) to retain the previous sampling period and move to setting the duration.

4. The **90-FLT** now prompts you to enter the duration in minutes. The current duration is displayed...

Enter Duration of Sampling (mins) : 10
Enter 0 for continuous

Use the Numeric Keypad to set the total duration for which the **90-FLT** will log readings into memory from 1 to 720 minutes. Alternatively, enter 0 to log continuously until logging is stopped by the user or the memory is full.

Press (Enter) to save the new duration.

Press (Menu) to quit and retain the previous duration.

5. The Sampling Period and Duration datalogging is now programmed, and can be started and stopped as required.

Starting and Stopping Sampling Period and Duration Datalogging

Starting and stopping Sampling Period and Duration datalogging is a two step process...

1. Press (F4) in normal measurement mode.
2. The **90-FLT** now prompts you to press (Enter) to begin logging. For example...

Press Enter to Sample every 5 seconds,
For 10 minutes, or Menu to Quit 12:00:00

The time is shown to enable the user to synchronise the sampling times if required.

4. Press (Enter) to start logging.

To stop logging before the end of the duration press (F4) .

Notes

1. The **90-FLT** remains switched on continuously for Sampling Period and Duration datalogging.
2. If the Dissolved Oxygen stirrer is enabled, it is switched on continuously for Sampling Period and Duration datalogging.

11.4 Recalling Readings from the Logger

To recall records from the Logger onto the 90-FLT display...

1. Select the Logger menu (Menu) → **F3:Logger**)
2. Select **F1:Recall** from the menu.

Record number 1 is now displayed.

The following example shows the display when the A & B Data Input function was switched off during logging...

```
10.00ppM  2.76mS   7.00pH   360.NTU  25.0°C
Log#1      F2:↑ F4:↓ 1000mV 18/10 12:00:00
```

The following example shows the display when “A” and “B” were both set to data during logging...

```
10.00ppM  2.76mS   7.00pH   360.NTU  25.0°C
1         A=1234 B=1234 1000mV 18/10 12:00:00
```

3. Press (F2) to display the next record.
Press (F4) to display the previous record.
Press and hold (F2) or (F4) to scroll continuously through the readings.
To display a specific record, type in the desired record number using the Numeric Keypad and press (Enter).
Press (F3) to send the displayed record to the RS232 port.

11.5 Erasing Records from the Logger

To erase records from the Logger...

1. Select the Erase Logger menu (Menu → **F3:Logger** → **F2:Erase**)
2. The **90-FLT** now displays the Erase menu, for example...

```

Erase Logger, ( 100 ) Select Option
F1:Erase All  F2:Erase Last  Menu Exits
  
```

The number of readings stored in the Logger is displayed. See the “100” in the example above.

3. Press **F1** to erase all of the readings stored in the Logger.
Press **F2** to erase the last recorded reading only.
Press **Menu** to quit without erasing any records.

11.6 Printing Records from the Logger to the RS232 Port

1. Connect one end of the RS232 cable to the **Charger** socket of the **90-FLT**.
2. Connect the other end of the RS232 cable to an RS232 Printer, or to the COM1 or COM2 ports of a PC.
3. Ensure that the baud rate for the printer or PC and the **90-FLT** are the same. If necessary, alter the baud rate of the **90-FLT** (see section 12.1).

The **90-FLT** uses XON/XOFF protocol. Ensure that the printer is set accordingly.

4. Select the Logger menu. (Menu → **F3:Logger**).
5. Select **F3:Print Log** from the menu or press **Print**.
6. Printing starts as soon as **F3** or **Print** is pressed. The display shows the word “**Printing**” until printing is completed.

12. RS232 Port

12.1 Setting the Baud Rate

1. Select the Baud Rate menu (Menu) → **F5:System** → **F3:Baud Rate**)
2. The available baud rates are listed, along with the RS232 port configuration...

```

Baud Rate:   F1:300  >F2:9600   F3:19200
8 bits, No Parity, 1 Stop bit, XON/XOFF
```

The arrow indicates the current selection.

3. Press (F1) to select 300 baud.
 Press (F2) to select 9600 baud.
 Press (F3) to select 19200 baud.
 Press (Menu) to quit and retain the current setting.

12.2 Sending Readings to the RS232 Port

Press (Print) to instantly send readings to the RS232 port whenever the **90-FLT** is in normal display mode.

Each time the **90-FLT** logs a reading, that reading is sent directly to the RS232 port.

Press (Print) while recalling data on the display (see section 11.4) to send that record to the RS232 port.

12.3 RS232 Configuration

The **90-FLT** RS232 configuration is 8 Bits, No Parity, 1 Stop Bit, XON/XOFF Protocol.

This information is displayed when setting the baud rate (see section 12.1)

12.4 Communication and Statistical Software

Communication between the **90-FLT** and a PC can be handled with any RS232 communication software. A TPS communication software package for Windows® is optionally available (part number 130086).

Once the data is saved to disk, the next problem is how to use it. The data sent by the **90-FLT** is formatted in fixed-width columns that can be imported by programs such as Microsoft® Excel® and Lotus 123®.

Help on importing the data into Microsoft® Excel® is provided in section 12.8 and the “excel.txt” file in the folder where you installed the WinTPS program.

12.5 Commands

The following commands can be sent from a PC to the **90-FLT**. Note that <cr> denotes carriage return and <lf> denotes a line feed.

Action	Command	Notes
Request current data	?D<cr>	Returns the current data of all parameters plus date and time from the 90-FLT . The log number returned is set to Zero.
Request logged data	?R<cr>	Returns all logged records from the 90-FLT memory. The data ends with the message ENDS<cr> . The Dissolved Oxygen stirrer will be Stopped.
Erase logged data	?E<cr>	Erases all logged records from the 90-FLT memory. Returns the message ERASED<cr> to confirm that the records have been erased.

Continued over the page...

RS232 Commands, continued...

Request status information	?S<cr>	Returns the model name, firmware version number, instrument serial number and number of logged readings in memory, for example... 90FLT•V9.0•T1234•6520•mASLB+v%<cr> where • are spaces. Note that the number of logged readings is right-justified. The meaning of the last group of characters is as follows...
		m Dissolved Oxygen stirrer output is enabled.
		A or P A indicates A & B function is enabled. P indicates A is set to Pond Number.
		S Unit is powering Dissolved Oxygen stirrer.
		L Automatic datalogging is enabled.
		B Low Battery warning.
		+ Extended datalogging function is fitted.
		v Battery volts is available with ?V command. % Indicates new 90 series.
Request GLP information	?G<cr>	Returns all calibration GLP information, plus the instrument model, serial number and current date (see section 12.7 for data format and hand-shaking).
Enable Rate per Day or Time of Day automatic datalogging	?J<cr>	Starts automatic datalogging when the 90-FLT is set up for Rate per Day or Time of Day automatic datalogging (see sections 11.3.1 and 11.3.2). The meter must then be powered down with the OFF key or with the ?K command (see below).
Disable Rate per Day or Time of Day automatic datalogging	?F<cr>	Stops automatic datalogging when the 90-FLT is set up for Rate per Day or Time of Day automatic datalogging (see sections 11.3.1 and 11.3.2).
Power ON	Any 10 characters	Switches the 90-FLT ON. A specific command is not available while the 90-FLT is off, so RS232 activity caused by the 10 characters switches the unit ON.
Power OFF	?K<cr>	Switches the 90-FLT OFF. Use the command after the ?G command (above) to actually start rate per Day or Time of Day automatic datalogging.
Turn Dissolved Oxygen stirrer ON	?M<cr>	Starts the Dissolved Oxygen stirrer to run continuously until stopped. The stirrer output must be enabled (see section 3.5.1)
Turn Dissolved Oxygen stirrer OFF	?N<cr>	Stops the Dissolved Oxygen stirrer.
Request battery volts	?V<cr>	Returns the current voltage level in the battery pack, for example... 7.20V<cr>
Positions of Data Fields	?P<cr>	Returns the number of data fields, along with their position and length. When the A&B Data Input function is disabled... 9,1,10,12,8,21,4,26,5,35,7,46,5,54,5,62,5,70,5 This denotes 8 fields, the first of which is at column 1 and is 10 characters long. The second field is at column 12 and is 8 characters long and so on. When the A&B Data Input function is enabled... 11,1,10,12,8,21,4,26,5,35,7,46,5,54,5,62,5,70,5,78,4,84,4
Data Column Header	?H<cr>	Returns a text string which can be used to provide headers for each data field. Spaces are included to ensure that the headers are correctly aligned with the data.

12.6 Data Format

Data is returned to the RS232 Port by the **90-FLT** in the following format.

Please note that a “ • ” shown anywhere in this section denotes one space.

```
dd/mm/yyyy•hh:mm:ss•LLLL•DDDDUuu•CCCCCCuuu•PPPPUuu•MMMMMuutttttuuu•TTTTTuul
aaaaA•bbbbB
```

where....

dd/mm/yyyy is the date, month and year data.

hh:mm:ss is the hours, minutes and seconds data.

LLLL is the Log Number, 4 characters, right justified. The **90-FLT** sends a Zero for instant readings (see section 12.2).

DDDD is Dissolved Oxygen data. 5 characters, right justified.

uuu is the Dissolved Oxygen units description, which can be any of the following...

ppm	for parts per Million readout without Salinity correction. Note the lower case “m”.
ppM	for parts per Million readout with Salinity correction applied. Note the upper case “M”.
%S•	for % Saturation readout.
%G•	for % Gaseous readout.

CCCCCC is Conductivity or TDS data. 7 characters, right justified.

uuu is the Conductivity/TDS units description, which can be either of the following...

uS•	for uS/cm Conductivity readout. All readings are converted to uS/cm to ensure that the data is logical when analysed with other programs.
ppM	for parts per Million TDS readout. All readings are converted to ppM to ensure that the data is logical when analysed with other programs.

PPPPP is pH data. 5 characters, right justified.

uu is the pH unit description, sent as “**pH**”.

MMMM is mV data. 5 characters, right justified.

uu is the mV unit description, sent as “**mV**”.

ttttt is Turbidity data. 5 characters, right justified.

uuu is the Turbidity unit description, sent as “**NTU**”.

TTTTT is Temperature data, 5 characters, right justified.

uu is the Temperature unit description. Sent as “**oC**” for measured temperature data, or “**oM**” for manual temperature data.

L is the Low Battery indicator. Sent as “**L**” when the battery is below 5.60 volts.

Caution : Data recorded with a low battery may be unreliable.

The **90-FLT** sends a space when the battery is above 5.60 volts.

Continued over the page...

Data format, continued...

aaaa	A-Data input, 4 characters, left justified.
A	A-Data input identifier. Sent as “ A ” for A-Data or “ P ” for Pond number. See section 11.1 for further details on the A and B Data input function.
bbbb	B-Data input, 4 characters, left justified.
B	B-Data input identifier. Sent as “ B ”. See section 11.1 for further details on the A and B Data input function.

Notes

1. The “**aaaaA**” and “**bbbbB**” sections of the data string are not sent at all when the A and B data input function is switched off (see section 11.1).
2. When requested by a PC with the ?D or ?R commands (section 12.5), the data is terminated with a carriage return.
3. When the data is sent by the **90-FLT** using the Print function (section 11.6) or the Instant Send function (section 12.2), the data ends with a carriage return and a line feed.

12.7 GLP Data Format

GLP information is returned as 12 lines terminated by a carriage return. When using the “?G” command (section 12.5), the computer must respond with a character after receiving each line.

For example...

```

90FLT V9.0 T1234 Turbidity Probe V1.0 T4321 @ 18/10/2006 14:00
Oxygen          Zero=          0.1%          @ 18/10/2006 12:00
Oxygen          Span=          100.0%         @ 18/10/2006 12:10
Conductivity    Zero=          0.01uS        @ 18/10/2006 12:20
Conductivity    k=            1.01          @ 18/10/2006 12:30
TDS             Zero=          0.01ppM       @ 18/10/2006 12:20
TDS             k=            1.01          @ 18/10/2006 12:40
pH              Asy=          0.10pH        @ 18/10/2006 12:50
pH              Slope=        99.0%         @ 18/10/2006 13:00
Turbidity Low   Zero=          0.1NTU        @ 18/10/2006 13:10
Turbidity Low   Span=          100.1%         @ 18/10/2006 13:20
Turbidity High  Zero=          0.NTU         @ 18/10/2006 13:30
Turbidity High  Span=          100.1%         @ 18/10/2006 13:40
Temperature     Offset=         1.0oC         @ 18/10/2006 13:50
Temperature     Span=          100.0%         @ 18/10/2006 14:00
Ends

```

12.8 Importing Data into Microsoft Excel

The following procedure details the method for importing a **90-FLT** text data file into Microsoft Excel®.

1. Start Microsoft® Excel® and select **File** → **Open**
2. In the “Files of type:” pull-down box, choose “Text Files (*.prn; *.txt; *.csv)”.
3. Navigate to the folder where your data file is stored and double-click it to start the Text Import Wizard.

Note : The default data folder for the WinTPS software is “C:\My Documents\WinTPS”.

4. In step 1 of the Text Import Wizard select “Fixed width”, as per the sample screen below, then press “Next >”.

Note that the data column headers in row appear only when the data is downloaded using the WinTPS software.

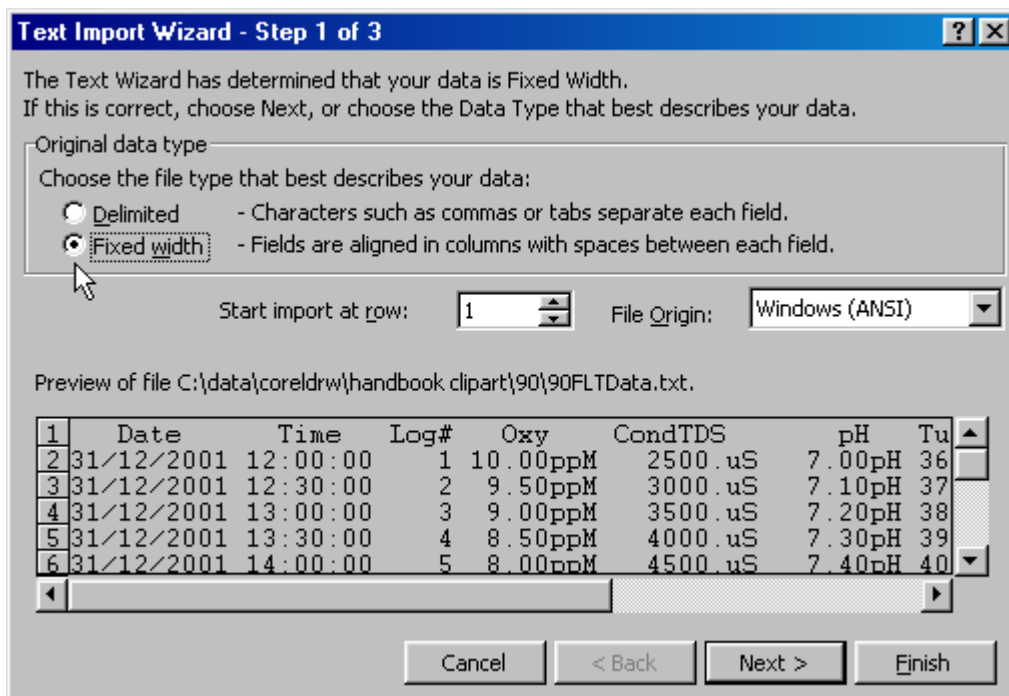

Continued over the page...

- Step 2 of the Text Import Wizard allows you to select the points at which each data field will break into a new column. The sample screens below show where TPS recommends the breaks be inserted. There are two screens, as the width of the data requires the window to be scrolled over.

The date and time have been incorporated into a single column to ensure that the X-axis is correctly formatted if the data is to be charted later.

Press “Next >” after all the column breaks have been inserted.

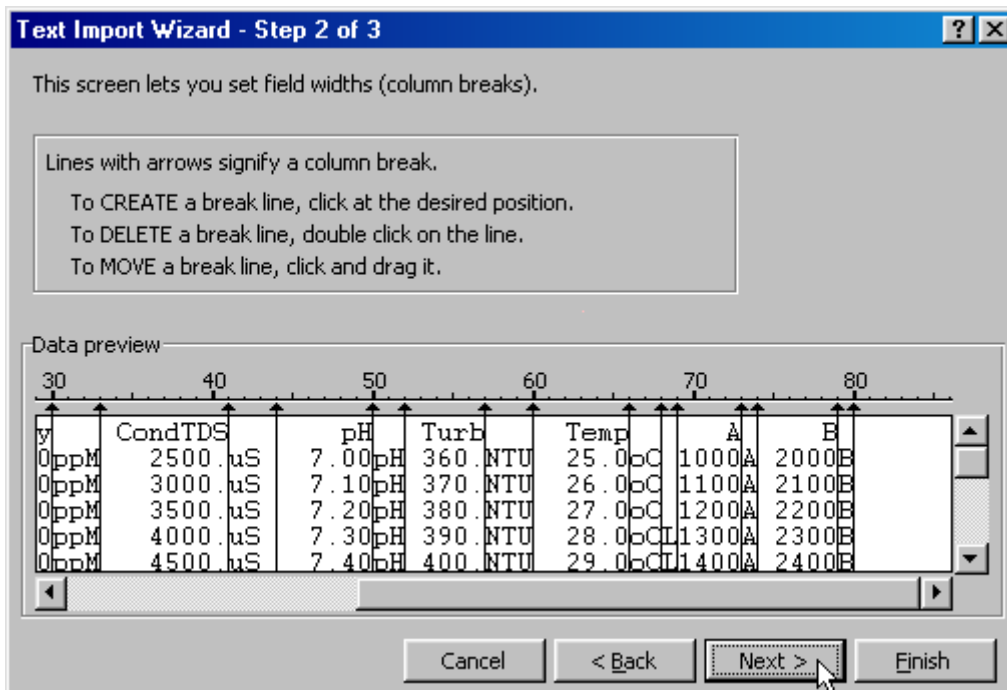
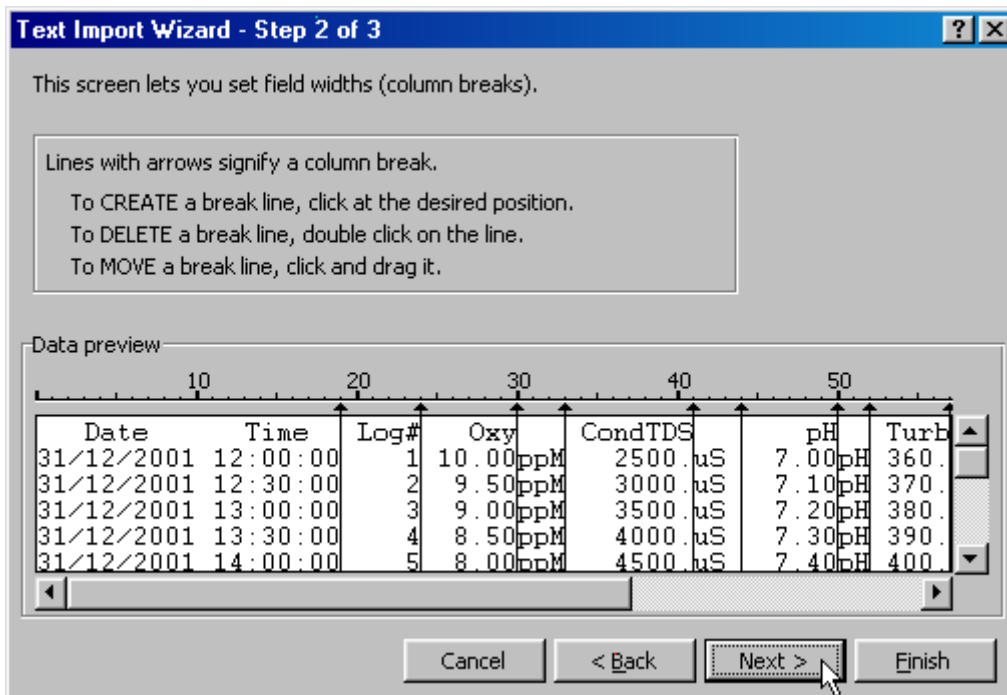

- Simply press “Finish” at step 3 of the Text Import Wizard. TPS recommends that the data format for each column be set once the data is in spreadsheet format.

For help on formatting the data columns, charting, graphing or other operations please consult the Microsoft® Excel® help file. Alternatively please contact TPS and we will try to provide further assistance.

13. Setting the Clock

1. Select the Clock Set-up menu (Menu → **F5:System** → **F2:Set Clock**)
2. The display now shows the current time, for example...

```
Time is now      12:00
Enter new Time  12:00
```

3. Use the Numeric Keypad to enter the current time in 24 hour format, then press **Enter**.
Alternatively, press (Menu) to quit and retain the current setting.

4. If you pressed **Enter** above, the display will now show the current date, for example...

```
Date is now      18/10/2006
Enter new Date  18/10/2006 dd/mm/yyyy
```

5. Use the Numeric Keypad to enter the current date in dd/mm/yyyy format, then press **Enter**.
Alternatively, press (Menu) to quit and retain the current setting.

Notes

1. Press the (←) key to make any corrections as required.
2. The **90-FLT** tests that a valid time of the day is entered. If an invalid time is entered (eg. 25:00), the **90-FLT** displays the message “**Invalid Time**”, then returns to the time setting screen so that the correct time can be entered.
3. The **90-FLT** tests that a valid day of the month is entered. If an invalid date is entered (eg. 18/10/2006), the **90-FLT** displays the message “**Invalid Date**”, then returns to the date setting screen so that the correct date can be entered.
4. The **90-FLT** also tests for leap years.

14. Initialising the 90-FLT

If the calibration settings of the **90-FLT** exceed the allowable limits, the unit may need to be initialised to factory default values. This action may be required if a sensor is replaced or if the memory is corrupted.

To initialise the **90-FLT**...

1. Select the GLP menu (Menu) → **F4:Setup** → **F2:GLP**).
2. Select **F4:Initialise Meter** from the menu.
3. The **90-FLT** will now ask if you are sure that you wish to initialise the unit...

Initialise Unit, Are you sure ?
F1:Yes F2:No

Press (F1) to initialise the **90-FLT** and reset all calibration data and erase all logged readings.

Press (F2) to quit and retain the current calibration settings and logged readings.

4. If **F1:Yes** was selected above, the **90-FLT** will display the number of logged readings in memory and provide an additional warning that these will be erased. For example...

Logger contains Data. 6520 readings
will be Erased. Continue ? F1:Yes F2:No

Press (F1) to initialise the **90-FLT** and reset all calibration data and erase all logged readings.

Press (F2) to quit and retain the current calibration settings and logged readings.

5. If **F1:Yes** was selected above, the **90-FLT** will display the following messages to indicated that the unit has been successfully initialised.

Initialising

then...

Initialised
Re-Calibrate unit before use.

then...

Turbidity Probe Calibration Reset.
Check Probe in Standard.

6. The meter then goes back to the GLP menu. When returning to display mode later, note that each of the decimal points has been replaced with a “ * ” to indicate that each parameter requires re-calibration.

15. Instrument firmware version number

If you need to phone or fax TPS for any further technical assistance, the version number of your **90-FLT** firmware may of benefit to us. The version number is displayed by the **90-FLT** at turn-on.

16. Battery Saver Function

The **90-FLT** is equipped with a battery saver function. If no button has been pressed for 5 minutes or 1 hour, the unit beeps and flashes the display for 20 seconds and then shuts off. This function can also be switched off for continuous use.

To program the battery saver function:



1. Select Battery Saver menu (Menu → **F5:System** → **F1:Bat. Saver**).
2. The battery saver menu is now displayed...

```
Battery Saver:  F1:OFF    >F2:5 minutes
Volts= 7.20V    F3:1 hour
```

The arrow indicates the current selection.

3. Press **F1** to disable the battery saver function for continuous use.
Press **F2** to set the battery saver function to 5 minutes. The meter will switch itself off if no key has been pressed for five minutes.
Press **F3** to set the battery saver function to 1 hour. The meter will switch itself off if no key has been pressed for 1 hour.
Press **Menu** to quit the battery saver menu and retain the current setting.

Notes

1. The  symbol flashes when the battery volts drops below 5.60 volts. At approximately 5.10 volts the meter turns itself off.
2. The accuracy of the data degrades when the  symbol is flashing. The **90-FLT** should not be used to take readings or calibrate while the  is flashing.

17. Moisture Protection

17.1 Silica Gel Pack

Due to the size of the **90-FLT** enclosure, it tends to expand in hot environments and contract in cold environments. This process can cause moist air to be drawn into the enclosure, which would then cause corrosion damage to the circuit.

To avoid this problem, TPS has mounted a breathing system inside the enclosure. This system consists of a long, thin tube which is vented to the atmosphere at one end and into a bottle of Silica gel at the other end. This ensures that the **90-FLT** breathes dry air. In humid environments, the Silica gel pack should be regularly checked.

To check the Silica gel pack...

1. Undo the 4 plastic screws on the rear of the unit.

2. Inspect the bottle of Silica gel.

Blue indicates that the Silica gel is still dry (proceed to step 5).

Pink indicates that the Silica gel is moist (proceed to step 3).

3. Empty the Silica gel into a microwave proof dish and place it into a microwave oven.

Place approximately 100mL water in a microwave proof cup into the microwave oven. This will absorb some of the microwave energy and stop the Silica gel balls bursting.

Turn the microwave oven ON using a moderate setting for approximately 1 minute, or until the Silica gel turns blue.

CAUTION : THE SILICA GEL MAY BE VERY HOT AT THIS POINT.



4. Remove the Silica gel from the microwave oven and allow to cool.

Pour the Silica gel back into the bottle and re-fit the bottle onto the rear cover of the instrument.

5. Re-fit the rear cover onto the instrument, ensuring that is the correct way around. The cover has locating lugs in two of the corners to make correct fitment simple.

18. Troubleshooting

18.1 General Errors

Error Message	Possible Causes	Remedy
Factory Calibration Data Failure	The EEPROM chip which contains the factory calibration information has failed.	The unit must be returned to TPS for service.
EEPROM Write Failure Return to Factory for Service	User calibration settings have been lost or corrupted.	Switch the meter OFF and switch back ON. If the problem persists, return the unit to TPS for service.
Flashing  symbol.	Battery is below 5.60 volts.	Recharge the battery. A full charge will take approximately 18 hours. Note that the unit will switch itself off when the battery falls below 5.10 volts. Data obtained while the  is flashing may be unreliable. Do not take readings or calibrate while the  is flashing.
Meter displays the word OFF , and switches off.	Battery is below 5.10 volts.	Recharge the battery. If this fails, check the charger. If charger is OK, replace the battery.
Meter will not turn on.	Battery is exhausted.	Recharge the battery for approximately 18 hours. If this fails, check the charger. If charger is OK, replace the battery.
Battery does not charge up when charger is connected.	<ol style="list-style-type: none"> 1. Faulty battery charger. 2. Faulty battery. 	<ol style="list-style-type: none"> 1. Connect the charger and switch the power on. 2. Display the battery volts in the battery saver menu (see section 16). 3. If the battery volts are increasing then the charger is OK. If the battery volts do not increase, then the charger is faulty. 4. Replace the charger or the battery, as required.

18.2 Dissolved Oxygen Troubleshooting

Symptom	Possible Causes	Remedy
Unit fails to calibrate, even with new sensor.	Calibration settings outside of allowable limits due to previous failed calibration.	Initialise the unit. See section 14.
<ul style="list-style-type: none"> • Zero calibration fails (Zero is greater than 7.0%) • Air calibration fails (Span is less than 65% or greater than 200%). • Unstable or inaccurate readings. 	<ol style="list-style-type: none"> 1. Membrane is leaking or broken. 2. Gap between membrane and gold cathode is dry. 3. Incorrectly fitted membrane. 4. Electrode is empty. 5. Electrode is faulty. 	<p>Replace membrane and refill electrode.</p> <p>Gently pump the pressure compensation diaphragm several times.</p> <p>Membrane should be smooth and convex with no wrinkles. Re-fit membrane if necessary.</p> <p>Replace membrane and re-fill electrode.</p> <p>Return electrode to factory for repair or replacement</p>
Blackened Silver anode.	Electrode has been exposed to sulphides or other chemical poisoning.	<p>Remove pressure compensation diaphragm and membrane, then soak in 5% Ammonia solution for 10 minutes.</p> <p>If cleaning is unsuccessful, return the sensor to the TPS factory for cleaning and service.</p>
Tarnished or scratched Gold cathode.	Electrode has been chemically poisoned or physically damaged.	Return to the TPS factory for cleaning and service.
Dissolved Oxygen reading flashes in ppM mode.	1. Conductivity/TDS reading is in excess of 82mS/cm or 50ppK.	Dissolved Oxygen readings are still valid and accurate, but no longer salinity-compensated, as the Conductivity/ TDS has exceeded the limit for accurate calculations.
Meter displays OVR ppM or OVR% instead of Dissolved Oxygen data.	<ol style="list-style-type: none"> 2. Electrode has not yet polarised. 3. Electrode is faulty 	<p>Wait for 2-3 minutes for the electrode to polarise after the 90-FLT is switched on.</p> <p>Return electrode to factory for repair or replacement.</p>

18.3 Conductivity / TDS Troubleshooting

Symptom	Possible Causes	Remedy
Unit fails to calibrate, even with new probe.	Calibration settings outside of allowable limits due to previous failed calibration.	Check that the k factor is set correctly when not using a TPS k=10 sensor. Initialise the unit. See section 14.
Unit attempts Span calibration instead of Zero calibration.	Sensor has Zero error.	Thoroughly rinse sensor in distilled water and allow to completely dry in air before attempting zero calibration. DO NOT rub the platinised electrode surfaces. If instrument does not calibrate at Zero with sensor disconnected, then the instrument is faulty.
Standard calibration fails, and k factor is greater than 25% <i>above</i> the nominal value.	<ol style="list-style-type: none"> Sensor is not immersed correctly. Sensor may have a build-up of dirt or oily material on electrode plates. Platinum-black coating has worn off. Standard solution is inaccurate. Sensor is faulty. Faulty instrument. 	<p>Immerse sensor correctly as per diagrams in section 4.4.</p> <p>Clean sensor as per the instructions detailed in section 19.2.1.</p> <p>Sensor requires replatinisation as per section 19.2.1. Alternatively, return to the factory for replatinisation.</p> <p>Replace standard solution.</p> <p>Return sensor to factory for repair or replacement.</p> <p>Return to factory for repair.</p>
Standard calibration fails, and k factor is greater than 25% <i>below</i> the nominal value.	<ol style="list-style-type: none"> Standard solution is inaccurate. Sensor may have a build-up of conductive material, such as salt. Sensor is faulty. Faulty instrument. 	<p>Replace standard solution.</p> <p>Clean sensor as per the instructions detailed in section 19.2.1.</p> <p>Return sensor to factory for repair or replacement.</p> <p>Return to factory for repair.</p>
Inaccurate readings, even when calibration is successful.	<ol style="list-style-type: none"> Sensor may have a build-up of dirt or oily material on electrode plates. Platinum-black coating has worn off. 	<p>Clean sensor as per the instructions detailed in section 19.2.1.</p> <p>Sensor requires replatinisation as per section 19.2.1. Alternatively, return to the factory for replatinisation.</p>
Readings drift.	Sensor may have a build-up of dirt or oily material on electrode plates.	Clean sensor as per the instructions detailed in section 19.2.1.
Readings are low or near zero.	<ol style="list-style-type: none"> Sensor may have a build-up of dirt or oily material on electrode plates. Sensor is not immersed correctly. Sensor is faulty. Faulty instrument. 	<p>Clean sensor as per the instructions detailed in section 19.2.1.</p> <p>Immerse sensor correctly as per diagrams in section 4.4.</p> <p>Return sensor to factory for repair or replacement.</p> <p>Return to factory for repair.</p>

18.4 Ph and Redox Troubleshooting

Symptom	Possible Causes	Remedy
Unit fails to calibrate, even with new pH probe.	Calibration settings outside of allowable limits due to previous failed calibration.	Switch the unit OFF and then back ON again and repeat calibration. Initialise the unit. See section 14.
1 Point calibration fails (pH asymmetry is greater than ± 1.00 pH.)	<ol style="list-style-type: none"> Reference junction blocked. Reference electrolyte contaminated. 	<p>Clean reference junction as per instructions supplied with the pH or reference electrode.</p> <p>Flush with distilled water and replace electrolyte.</p>
2 Point calibration fails. (pH slope is less than 85.0%.)	<ol style="list-style-type: none"> pH Buffers not correctly set. pH glass bulb not clean. Electrode is aged. Connector is damp. pH Buffers are inaccurate. 	<p>For automatic pH buffer recognition, ensure that you are using buffers that match the selected buffer set (see section 6.1). Otherwise, ensure that the buffer value is entered correctly at pH calibration.</p> <p>Clean sensor surface or glass bulb as per instructions supplied with the electrode.</p> <p>Attempt rejuvenation as per instructions supplied with the electrode. If unsuccessful, replace electrode.</p> <p>Dry in a warm place.</p> <p>Replace buffers.</p>
Unstable readings.	<ol style="list-style-type: none"> Reference Electrolyte chamber needs to be refilled. Reference junction blocked. pH glass bulb or Redox platinum tip not clean. Bubble in pH glass bulb. Faulty connection to meter. Reference junction not immersed. KCl crystals around reference junction inside the electrolyte chamber. 	<p>Refill with saturated KCl filling solution.</p> <p>Clean reference junction as per instructions supplied with the electrode.</p> <p>Clean glass bulb or platinum tip as per instructions supplied with the electrode.</p> <p>Flick the electrode to remove bubble.</p> <p>Check connectors. Replace if necessary.</p> <p>Ensure that the reference junction is fully immersed. See diagram in section 6.2 or 7.1.</p> <p>Rinse electrolyte chamber with warm distilled water until dissolved. Replace electrolyte.</p>
Inaccurate readings, even when calibration is successful.	Reference junction blocked.	Clean reference junction as per instructions supplied with the electrode.
Displays constant reading around pH7.00 or 0 mV for all solutions.	Electrical short in connector.	<ol style="list-style-type: none"> Check connector. Replace if necessary. Replace electrode.
Displays 4-5 pH for all solutions.	pH electrode glass bulb or internal stem cracked.	Replace pH electrode.

18.5 Turbidity Troubleshooting

Symptom	Possible Causes	Remedy
Turbidity cannot be calibrated, or readings inaccurate	<ol style="list-style-type: none"> 1. Turbidity standard is incorrect. 2. Turbidity sensor is dirty. 3. Turbidity sensor is not immersed correctly. 	<p>Check Turbidity standards. Zero calibration must be performed in fresh Distilled water. Check that the Turbidity standard has been correctly entered (section 8.1).</p> <p>Clean tip of Turbidity sensor with a clean, soft cloth. Avoid scratching the sensing surface.</p> <p>Turbidity sensor must be at least 30mm above the floor of the sample vessel.</p>
Turbidity reading replaced by “No Probe”, when sensor is connected.	<ol style="list-style-type: none"> 1. Cable not connected correctly. 2. Faulty cable. 3. Faulty sensor. 	<p>Check that cable is correctly connected at the meter and at the sensor ends.</p> <p>Return cable to the TPS factory for repair or replacement.</p> <p>Return sensor and cable to the TPS factory for repair or replacement.</p>

18.6 Temperature Troubleshooting

Symptom	Possible Causes	Remedy
Temperature inaccurate and cannot be calibrated.	<ol style="list-style-type: none"> 1. Faulty connector. 2. Faulty Conductivity or Temperature sensor, whichever is being used. 	<p>Check the connector and replace if necessary.</p> <p>Return Conductivity or Temperature sensor for repair, or replace sensor.</p>
Displays manual temperature setting (eg. 25.0°C) when Conductivity or Temperature sensor plugged in.	<ol style="list-style-type: none"> 1. Faulty instrument socket. 2. Faulty Conductivity or Temperature sensor, whichever is being used 	<p>Return the instrument to the TPS factory for service.</p> <p>Return Conductivity or Temperature sensor for repair, or replace sensor.</p> <p>NOTE Conductivity and TDS readings may still be accurate, as there is a separate temperature sensor to provide ATC for these parameters built into the Conductivity/TDS sensor.</p>

19. Appendices

19.1 Dissolved Oxygen

19.1.1 Dissolved Oxygen Sensor Fundamentals

The electrode used is the amperometric type of Clark Electrode and is suitable for the measurement of oxygen pressures in the range 0 to 100 cm of mercury. While the probe actually reads partial pressure of oxygen, the circuit is calibrated to be read in percentage saturation or parts per million (Milligrams/litre). The operation of the Clark type probe relies on the diffusion of oxygen through a suitable membrane into a constant environment of potassium chloride. Solution measurements are best performed with a reasonable flow past the membrane. At sufficiently high flow rates, the oxygen current is totally independent of the flow (a few cm/sec is sufficient). The cell must not be shaken however or unstable readings will result from electrolyte surge bringing new oxygen from the reservoir to the working cathode surface.

19.1.2 Operating Principle

The Clark oxygen electrode consists of a gold cathode and a silver/silver chloride anode, placed in an electrolyte solution. This solution is contained behind a plastic membrane. In this case the plastic is 0.001 inch PTFE (Teflon) sheet. It must be realised that using membranes of very different thicknesses will result in an error in the temperature compensation that is applied in the instrument for the membrane permeability. This coefficient is $+4.2\%/^{\circ}\text{C}$ at 25°C for this thickness membrane.

A polarising voltage of about 800 millivolts is applied between the two electrodes. The gold electrode is placed close to the membrane and because of the polarising voltage, oxygen diffusing through the membrane will be reduced at the gold electrode.



This reduction process will produce a current through the oxygen electrode. A load resistor (actually a thermistor in this case) situated in the electrode itself, converts this current into a voltage proportional to the oxygen partial pressure. The thermistor provided within the body of the electrode has a temperature coefficient of $-4.2\%/^{\circ}\text{C}$. This gives an accurate temperature compensation for the temperature/permeability effect of the membrane, over a range of about 5 to 45°C about a centre value of 25°C . Note this compensation is not for the solubility effects. A separate sensor also built into the tip of the probe achieves this.

19.1.3 Probe Storage

The Oxygen probe should be kept moist when not in use to prevent the thin film of electrolyte behind the membrane from drying out. To achieve this, the probe can be stored with the tip in water or in a humid environment.

For long term storage of several weeks or more, remove the membrane and empty out the electrolyte. Replace the membrane without electrolyte to avoid contamination of the gold and silver surfaces. When the electrode is stored in this way, the membrane should be replaced and the electrode refilled before use.

19.1.4 Maintenance Of The Membrane

The membrane does not require replacement as long as it remains intact. If punctured or suspected of leaking around the edges, it must be replaced. To replace the membrane, please see the separate instruction leaflet supplied with your sensor.

19.1.5 Notes On Units Of Dissolved Oxygen

The terms "Oxygen Concentration" and "Oxygen Partial Pressure" frequently give rise to some confusion.

- Oxygen Concentration is the absolute quantity of oxygen present per unit mass of the liquid.
- Oxygen Partial Pressure is the oxygen fraction of the total pressure of all of the gases present.

For any one liquid system, Oxygen Concentration and Oxygen Partial Pressure are proportional. However, if the solubility of oxygen in the liquid should change owing to increased quantities of solutes, etc., then the ratio of the Concentration to the Partial Pressure must change. Thus, if one saturates distilled water and a 25% solution of Sodium Chloride with air at atmospheric pressure (25°C) both solutions will have almost exactly the same Oxygen Partial Pressure, namely 15.5 cm of mercury. However, the dissolved Oxygen Concentration parts per million (milligrams per litre) will be 8.2 in the distilled water and 2.01 in the salt solution. This is a rather extreme example, as ocean water is only 3.6% saline. It does however stress the importance of correct interpretation of the salinity.

The Clark Electrode measures the partial pressure of oxygen diffusing through a membrane. The current is a linear measure of this partial pressure, assuming sufficient liquid flow conditions.

With air at sea level, the 20.9% oxygen exerts about 15.5 cm of Mercury pressure. Water in equilibrium with air and with no oxygen demand (C.O.D., B.O.D. etc.), is saturated and has this dissolved oxygen partial pressure. If we define 100% Saturation in Partial Pressure terms, then 15.5 cm. Hg = 100% Saturation. This is a practical unit to use. The probe linear readout is then a linear function of % Saturation. Organic cell walls behave like the probe and pressure units are valuable.

% Saturation is the best unit for industrial control and not ppM, contrary to popular beliefs. The partial pressure (and consequently the pressure defined % Saturation) varies only slightly with temperature. (Recall at this stage that the permeability of the membrane has a temperature coefficient, but the electronics has scaled this out by the operation of the Automatic Membrane Temperature Compensator Thermistor incorporated in the D.O. probe).

If mass units are used for measurement of Dissolved Oxygen, the temperature problem of relating the linear partial pressure reading of the probe to the mass (ppM or mg/L) at different temperatures becomes more involved. As well, there is the mass variation due to dissolved salts (salinity correction). Therefore, the fully corrected instrument would need 3 correction systems.

- (a) Membrane correction for temperature permeability effects ;
- (b) Solubility correction of Dissolved Oxygen with temperature and ;
- (c) Salinity correction of Dissolved Oxygen by weight (Salinity has no effect on pressure units readout).

In the **90-FLT** instrument,

- (a) Membrane correction is achieved AUTOMATICALLY ;
- (b) To provide the mass units (ppM) readout (so popular due to the Winkler process used in the past), the **90-FLT** Meter has Solubility Correction via an additional temperature sensor in the electrode ;
- (c) Salinity correction is performed automatically via the Conductivity/TDS sensor.

19.1.6 Equilibrium Conditions

Whilst Saline Water has a lower ppM than does Fresh Water, it does not mean it necessarily has less biologically available oxygen. Both have 100% Saturation (presuming no Chemical Oxygen Demand (C.O.D.), Biological Oxygen Demand (B.O.D.), etc.) because both are in partial pressure equilibrium with air. Any usage of oxygen is immediately replenished by the dissolving of more from air to meet partial pressure equilibrium requirements. This is so for both saline and fresh water. The reporting of oxygen at a lower level (in ppM units) in the Salt Water is therefore **QUITE MISLEADING !**

In closed systems, such as tanks, pipes and deep waters, equilibrium is not so readily available and the Salinity Effect gains the importance in the reporting of Dissolved Oxygen. It is suggested, unless such closed (or deep, low diffusion) systems are encountered, that Oxygen should be reported in % Saturation or ppM of equivalent Fresh Water.

19.1.7 Velocity Past The Membrane

Workers have shown that the relationship between the diffusion current (oxygen current) and the external velocity of the liquid is exponential. Some workers using thicker membranes have shown even less dependence of the diffusion current on liquid velocity. Because of the exponential nature of the relationship, considerable changes in velocity have to be made before noticing any change in the diffusing current once the flow is sufficiently high. Tests with this electrode have shown that flow rates above 0.2 litres/minute past the membrane give results indistinguishable from those with appreciably higher flow rates (5 litres/minute). Fluctuations in readings due to air bubbles passing through the membrane are a different matter, however.

With the type of electrode to be used with this instrument, very little change in diffusion current is caused by altering the pH of the external environment. Pressure changes over a moderate range exerted on the membrane also cause no change. The EDYSI has a pressure compensation diaphragm to allow submersion to 60 metres.

19.2 Conductivity/TDS

19.2.1 Care, Cleaning and Maintenance of Conductivity Sensors

Care of Conductivity sensors

The conductivity section of the sensor supplied with your **90-FLT** consists of two platinum plates that are plated with a layer of “platinum-black”. This is quite a soft layer and is required for stable, accurate measurements. In time, the platinum-black layer may wear off in some applications, at which time the sensor will require replatinising (see detail later in this section). You can help to maintain the platinum-black layer by following these simple rules:

1. **NEVER** touch or rub the electrode plates with your fingers, cloth etc.
2. Avoid using the sensor in solutions that contain a high concentration of suspended solids, such as sand or soil, which can abrade the electrode plates. Filter these types of solutions first if possible.
3. Avoid concentrated acids. If you must measure acids, remove the sensor immediately after taking the measurement and rinse well with distilled water.

Conductivity sensors can be stored dry. Ensure that the sensor is stored in a covered container, to avoid dust and dirt build-up.

Cleaning of Conductivity Sensors.

Platinised platinum Conductivity sensors can only be cleaned by rinsing in a suitable solvent.

DO NOT wipe the electrode plates, as this will remove the platinum-black layer.

1. Rinsing in distilled water will remove most build-ups of material on the electrode plates.
2. Films of oils or fats on the electrode plates can usually be removed by rinsing the sensor in methylated spirits.
3. Stubborn contamination can be removed by soaking the sensor in a solution of 1 part Concentrated HCl and 10 parts distilled water. The sensor should not be soaked for more than approximately 5 minutes, otherwise the platinum-black layer may start to dissolve.
4. If all of these methods fail, then the last resort is to physically scrub the electrode plates, which will remove the contaminant and the layer of platinum-black. Use only a cloth or nylon scouring pad. **DO NOT USE STEEL WOOL**. The sensor will then need to be cleaned in HCl, as per step 3 and replatinised (see detail later in this section).

Replatinising Conductivity Sensors

There are several ways to replatinise Conductivity electrodes.

1. The simplest way is to return the electrode to the TPS factory. We can fully clean the electrode, replatinise it and test all aspects of its performance.
2. An automatic replatiniser is available from TPS, along with replatinising solution. This will plate the electrodes for the right amount of time at the correct current. Ordering details are as follows...

Automatic Conductivity Electrode ReplatiniserPart No 122160
 20mL Platinising Solution (suitable for approx 30 uses).....Part No 122300

3. Conductivity electrodes can be manually replatinised, according to the following procedure...
 - (a) Soak the electrode in a solution of 1 part Concentrated HCl and 10 parts distilled water for approximately 5 minutes.
 - (b) Rinse the electrode well in distilled water.
 - (c) Immerse the electrode in platinising solution at least to the vent hole in the body. Platinising solution is available from TPS (part no 122300). Alternatively, platinising solution can be prepared by dissolving 1g of Hydrogen Chloroplatinate (H_2PtCl_6) in 30mL of distilled water, and including about 0.01g of Lead Acetate ($(CH_3COO)_2Pb$) and a drop or two of concentrated HCl. **Caution : This is a dangerous solution and should be handled with the utmost care.**
 - (d) Apply a direct current of 10mA between pins 7 and 8 of the electrode plug, as per the diagram below. Reverse the polarity every 30 seconds. After approximately 8 minutes (4 minutes per electrode plate), they should have an even “sooty” appearance. Avoid excess current as this will cause incorrect platinising.
 - (e) After platinising, rinse the electrode well in distilled water.
 - (f) If you have any doubts about any of these steps, then you should consider returning the electrode to the factory. The cost of replatinising is quite low, and you will be guaranteed of the best possible result.

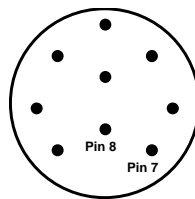

Sensor Connector

19.3 pH

pH electrodes are generally combination electrodes, where the pH sensing membrane and the reference system are contained in a single body. The sensing membrane is the round or spear shaped bulb at the tip of the electrode. This produces a voltage that changes with the pH of the Solution. This voltage is measured with respect to the reference section. The reference section makes contact with the sample solution using a salt bridge, which is referred to as the reference junction. A saturated solution of KCl is used to make contact with the sample. It is vital that the KCl solution has an adequate flow rate in order to obtain stable, accurate pH measurements.

19.3.1 Asymmetry of a pH or Specific Electrode

An “ideal” pH electrode produces 0 mV output at 7.00 pH. In practice, pH electrodes generally produce 0 mV output at slightly above or below 7.00 pH. The amount of variance from 7.00 pH is called the asymmetry.

Figure 19-1 illustrates how asymmetry is expressed for a pH electrode.

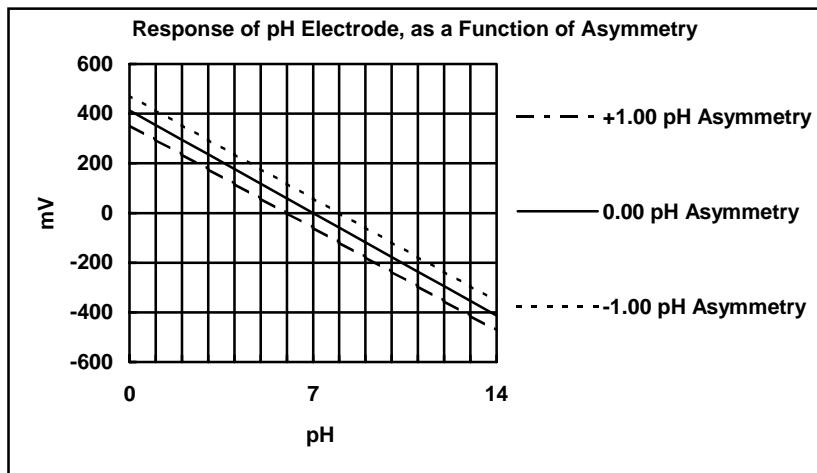

Figure 19-1

19.3.2 Slope of a pH Electrode

As mentioned above, a pH electrode produces 0 mV output at around 7.00 pH. As the pH goes up, an “ideal” pH electrode produces -59.16mV/pH unit at $25\text{ }^{\circ}\text{C}$. As the pH goes down, an ideal pH electrode produces $+59.16\text{mV/pH}$ unit. In practice, pH electrodes usually produce slightly less than this. The output of a pH electrode is expressed as a percentage of an ideal electrode. For example, an ideal electrode that produces 59.16mV/pH unit has “100% Slope”. An electrode that produces 50.15mV/pH unit has “85% Slope”.

Figure 19-2 illustrates the principle of electrode slope, using a pH sensor as an example.

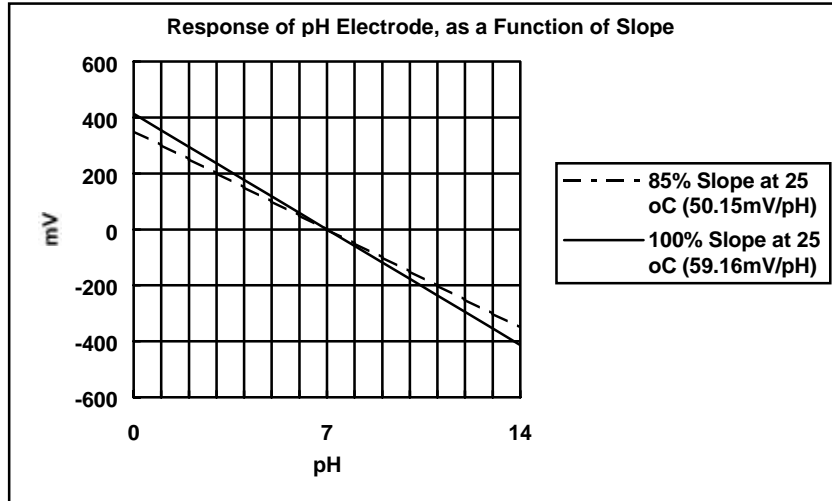

Figure 19-2

19.3.3 Temperature Compensation

The slope of a pH electrode is affected by temperature. This effect is compensated for either by using an Automatic Temperature Compensation (ATC) probe. Figure 19-3 shows the slope of a pH electrode at various temperatures.

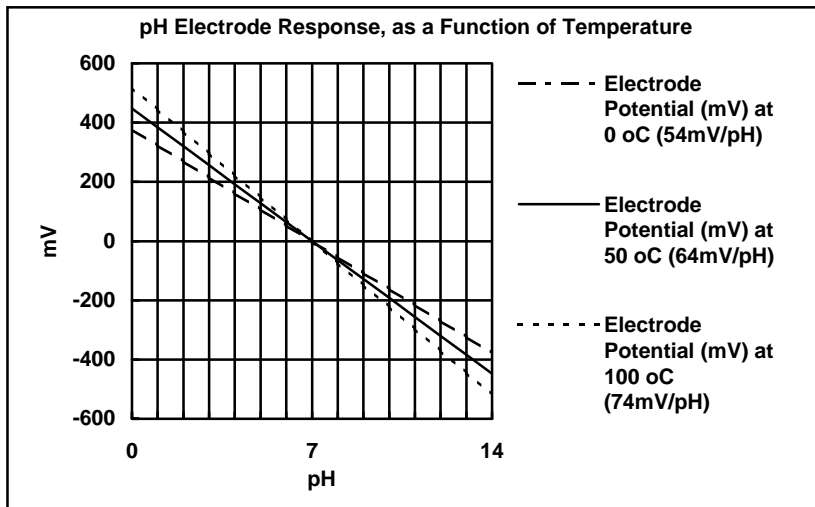

Figure 19-3

19.3.4 Checking the reference junction of a pH electrode

If pH readings are inaccurate or unstable, the reference junction of the electrode may be blocked. The following test can be performed to determine if the reference junction of a pH electrode is making adequate contact with the sample solution.

1. Calibrate the **90-FLT**, as per section 6.2.
2. Dilute 1 part of pH6.88 buffer with 9 parts of distilled water.
3. Measure the pH of the diluted buffer. The result should be 7.06 +/-0.05 pH.
4. If the value obtained is outside of these limits, then clean the reference junction as per the instructions supplied with the pH electrode.
5. Re-calibrate the **90-FLT** and repeat the test.
6. If the value obtained is still outside 7.06 +/-0.05 pH, then the electrode should be replaced.

19.3.5 *Determining if an instrument or electrode is faulty*

The following test can be performed to help determine if the **90-FLT** or the pH electrode is faulty.

1. Initialise the **90-FLT** (see section 14).
2. Disconnect the pH electrode from the **pH** connector.
3. Connect the centre pin of the **pH** connector with the outside frame of the connector, using a short piece of wire or a paper clip etc.
4. The meter should display approximately pH7.00, depending on the current calibration settings.
5. If the **90-FLT** is operating correctly, the reading should be totally stable with the wire firmly in place. If not, the meter requires servicing.
6. Now carefully disconnect the wire from the centre pin only (make sure the other end of the wire remains connected to the outside frame of the connector).
7. After an initial jump, the reading should steadily drift away from 7.00 (either up or down) at a rate of approximately 1 pH or less every 3 seconds. If the drift rate is faster than this, the input circuitry of the **90-FLT** is faulty and requires servicing.

20. Warranty

TPS Pty. Ltd. guarantees all instruments and electrodes to be free from defects in material and workmanship when subjected to normal use and service. This guarantee is expressly limited to the servicing and/or adjustment of an instrument returned to the Factory, or Authorised Service Station, freight prepaid, within twelve (12) months from the date of delivery, and to the repairing, replacing, or adjusting of parts which upon inspection are found to be defective. Warranty period on electrodes is three (3) months.

There are no express or implied warranties which extend beyond the face hereof, and TPS Pty. Ltd. is not liable for any incidental or consequential damages arising from the use or misuse of this equipment, or from interpretation of information derived from the equipment.

Shipping damage is not covered by this warranty.

PLEASE NOTE:

A guarantee card is packed with the instrument or electrode. This card must be completed at the time of purchase and the registration section returned to TPS Pty. Ltd. within 7 days. No claims will be recognised without the original guarantee card or other proof of purchase. This warranty becomes invalid if modifications or repairs are attempted by unauthorised persons, or the serial number is missing.

PROCEDURE FOR SERVICE

If you feel that this equipment is in need of repair, please re-read the manual. Sometimes, instruments are received for "repair" in perfect working order. This can occur where batteries simply require replacement or re-charging, or where the electrode simply requires cleaning or replacement.

TPS Pty. Ltd. has a fine reputation for prompt and efficient service. In just a few days, our factory service engineers and technicians will examine and repair your equipment to your full satisfaction.

To obtain this service, please follow this procedure:

Return the instrument AND ALL SENSORS to TPS freight pre-paid and insured in its original packing or suitable equivalent. INSIST on a proof of delivery receipt from the carrier for your protection in the case of shipping claims for transit loss or damage. It is your responsibility as the sender to ensure that TPS receives the unit.

Please check that the following is enclosed with your equipment:

- **Your Name and daytime phone number.**
- **Your company name, ORDER number, and return street address.**
- **A description of the fault. (Please be SPECIFIC.)**
(Note: "Please Repair" does NOT describe a fault.)

Your equipment will be repaired and returned to you by air express where possible.

For out-of-warranty units, a repair cost will be calculated from parts and labour costs. If payment is not received for the additional charges within 30 days, or if you decline to have the equipment repaired, the complete unit will be returned to you, not repaired. For full-account customers, the repair charges will be debited to your account.